

## “KEEPER” Safety Light Curtain with multi beams

### Instruction use and maintenance

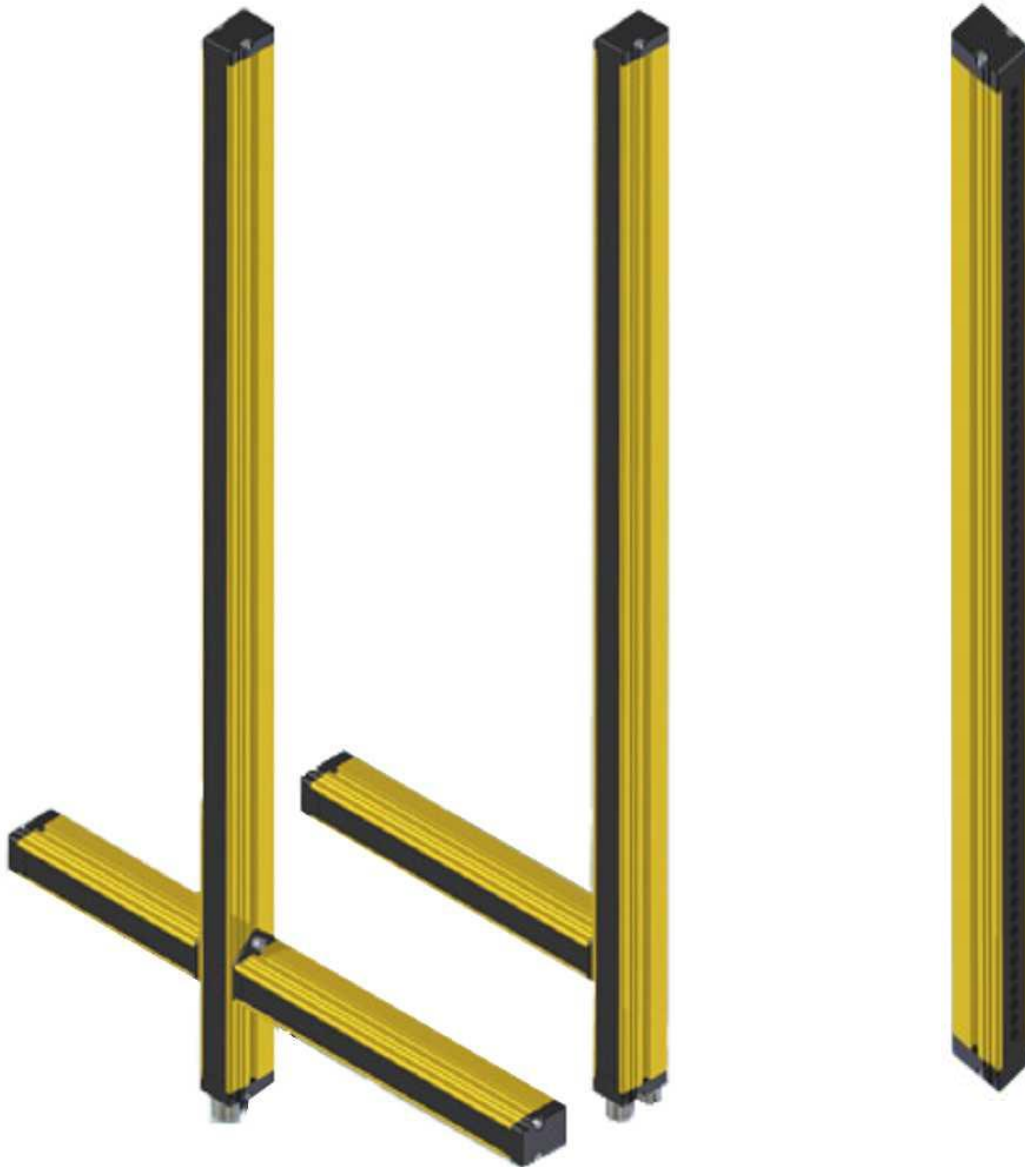

---

## IMPORTANT REMARKS ON SAFETY

---

### KEEPER - ORIGINAL INSTRUCTIONS

As this device, for the safety of operators working on dangerous machinery, it is necessary that an authorised person should carry out the installation carefully while making notes and maintain such records for future instruction and maintenance.

The safety light curtain forms only one link of the safety system.

Therefore, complete system performance remains the responsibility of the machine builder or end user.

Please observe all technical details and recommendations reported in this installation/instruction manual without exception and with strict adherence to all applicable local, National and International Safety Standards and guidelines which may apply to the machines.

**GREIN is not responsible for any dangerous occurs to not good employ of the materials.**

## Summary

GENERAL INFORMATIONS	pag. 4
TERMS AND DEFINITIONS	pag. 4
TECHNICAL CARATTERISTICS / OPTIONS	pag. 5
INSTALLATION GUIDELINES	pag. 6
DETERMINATION OF SAFETY DISTANCE	pag. 7
MINIMUM DISTANCE TO AVOID REFLECTIONS	pag. 8
MECHANICAL ASSEMBLY	pag. 9
GROUPING OF LIGHT CURTAINS	pag. 9
OVERVIEW KEEPER MODELS AND FUNCTIONS	pag. 10
CONFIGURATION - FUNCTIONS - CONNECTIONS	pag. 11
OVERALL DIMENSIONS MUTING ARMS	pag. 14
WIRING CONNECTION	pag. 16
EMITTER CONNECTIONS AND FUNCTIONS	pag. 21
RECEIVER CONNECTIONS AND FUNCTIONS	pag. 21
INDICATIONS AND DIAGNOSTIC	pag. 27
SERVICE AND TEST	pag. 31
SETTING UP AND TEST	pag. 32
LIST OF MODELS AND CHARACTERISTICS	pag. 33
EXTERNAL MUTING DETAILS	pag. 37
INTERNAL MUTING DETAILS	pag. 39
INTERNAL AND EXTERNAL MUTING COMBINATION	pag. 47
MUTING ARM REGULATION	pag. 47
ACCESSORIES - BRACKETS	pag. 48
CONNECTION CABLES	pag. 51
INTEGRATED SIGNALLING LAMP	pag. 51
RELAYS MODULE DIN RAIL	pag. 52
WARRANTY	pag. 58
UE DECLARATION	pag. 59

## GENERAL INFORMATIONS

The KEEPER multibeam safety barrier is an optoelectronic system ( **Electro Sensitive Protective Equipment** ) type 4 for the protection of worker exposed to dangerous machinery or equipment in accordance with current regulations on industrial safety.

KEEPER is formed by a transmitter and a receiver unit synchronized through a optical link. The safety outputs are solid state with the possibility to convert them into outputs relays using the appropriate optional modules. Are available interconnect modules to interface directly with the barrier without going through the electrical cabinet.

The advanced possibilities of the muting make this safety barriers ideal in automatic handling and storage. The wide range of models allows their use for the protection of the fingers, hand, arm and body. The main areas of application are: robotized areas, palletizers, automated warehouses, etc.

## TERMS AND DEFINITIONS

<b>OSSD0</b>	Safety output channel zero.
<b>OSSD1</b>	Safety output channel one.
<b>OSSD ON</b>	Condition on which the output permits the flow of current.
<b>OSSD OFF</b>	Condition on which the output don't permit the flow of current.
<b>EDM</b>	External Device Monitor.
<b>RESET</b>	OSSD restart from OFF to ON.
<b>MUTING</b>	Temporary suspension of the safety function.
<b>OVERRIDE</b>	Manual muting function after a mistake in automatic muting.

<b>Protective height</b>	<b>PH</b> It is the zone in which the test rod will stop the barrier.
<b>Sensitive height</b>	<b>SH</b> It is the zone covered by the beams.
<b>A</b>	Active part of the lens.
<b>B</b>	Beam spacing in mm.
<b>Resolution</b>	<b>d</b> It is the minimum object detected on protected area, Is the dimension necessary for the obscuration of two adjacent beams. $d = A + B$

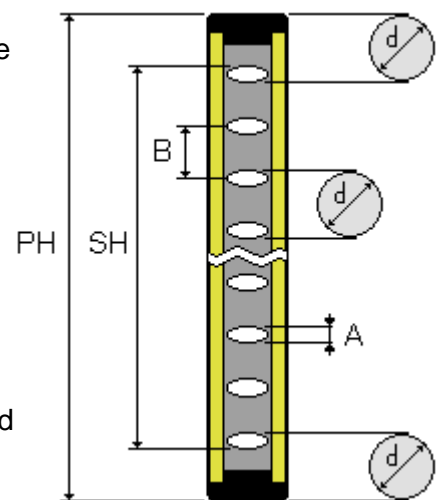

## Technical characteristics and functions

<b>Synchronization Tx Rx</b>	Optical
<b>Total aperture angle</b>	5°
<b>Wave length</b>	940 nm
<b>Resolutions</b>	14, 30, 55, 175, 320 mm
<b>Maximum range</b>	0.5 - 2.5 m across beam muting, 0.5 - 5 m parallel beam muting
<b>Power supply</b>	24 Vdc ± 10%
<b>Consumption tx + rx</b>	400 mA max, load excluded
<b>Response time</b>	From 6 to 16 ms depending to number of beams
<b>Max connections length</b>	100 m
<b>Body</b>	Extruded aluminium, 36 x 50, yellow RAL 1.021
<b>IP protection degree</b>	IP 65
<b>Relative humidity</b>	5 - 95% functioning and storage
<b>Working temperature</b>	-10 ÷ 65 °C non condensing
<b>Storage temperature</b>	-20 ÷ 70 °C
<b>Safety level</b>	Type 4 - SIL 3 - SILCL 3 - PL e - Cat. 4

<b>Emitter</b>	
<b>Connector</b>	M12 4 poles
<b>TEST</b>	Simulation of interruption of light curtain beams barrier, to facilitate the monitoring of the safety of the machine

<b>Receiver</b>	
<b>Connector</b>	M12 5 + 8 poles
<b>Reset</b>	Selection of the restart of the barrier
<b>Type</b>	Automatic or manual
<b>Restart time</b>	100 ms
<b>Static Output</b>	2 PNP - 500 mA short circuit and overload protected
<b>EDM</b>	External contactor control
<b>BARGRAPH</b>	At 3 L.E.D. for alignment and diagnostic
<b>External Muting type</b>	Two sensors, with contemporaneity control
<b>Override</b>	Manual override of muting function
<b>Muting lamp output</b>	Output for muting lamp, 24 V 500 mA max

## Other functions

<b>MUTING</b>	Temporary exclusion of the light curtain
<b>Internal muting LX</b>	L with 2 sensors, contemporaneity muting activation
<b>Internal muting LP</b>	L with 2 sensors, sequential muting activation
<b>Internal muting TX</b>	T with 2 sensors, contemporaneity muting activation
<b>Internal muting TP</b>	T with 4 sensors, sequential muting activation
<b>Muting enable</b>	Enable / disable the muting function
<b>Muting timeout</b>	Setting of max muting time ( 1 minute, 90 minutes, 24 hours )
<b>OSSD-S</b>	Output signaling of the safety outputs state
<b>MUTE - F</b>	Output for signaling of interrupted barrier when muting is active mainly used to indicate the presence of a pallet ready at the output

## INSTALLATION GUIDELINES

### Correct Installations

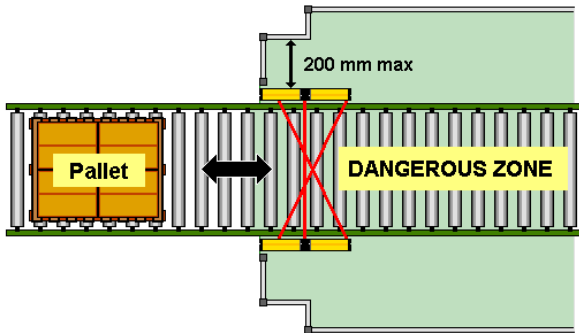

T model with across beams ( entry or exit )

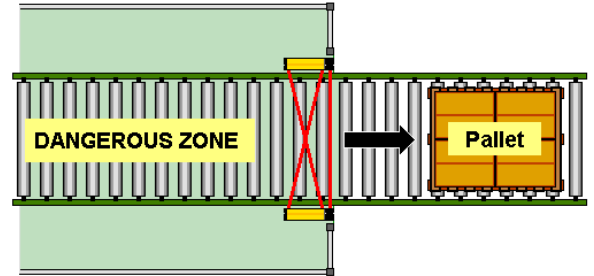

L model with across beams ( exit )

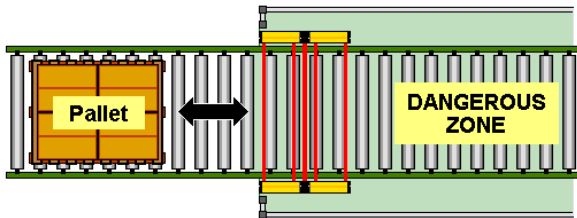

T model with parallel beams ( entry or exit )

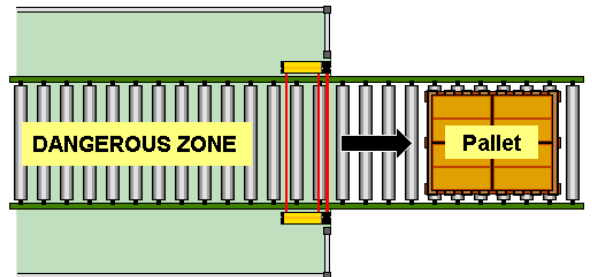

L model with parallel beams ( exit )

### Incorrect installations

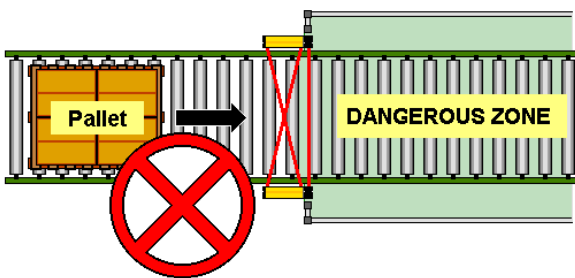

L - Incorrect use in entry

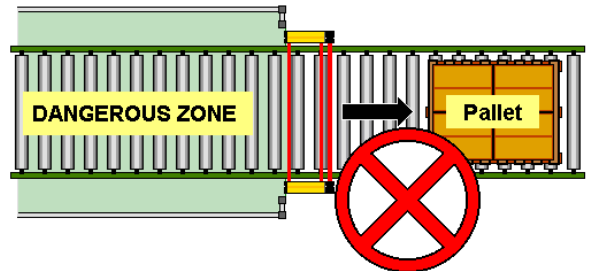

Insufficient mechanical protection

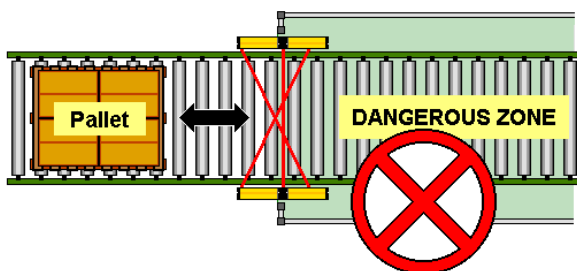

Wrong orientation T crossed beams

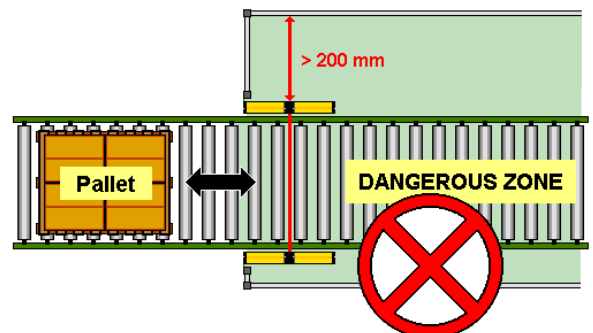

Mechanical protection incorrect

## DETERMINATION OF SAFETY DISTANCE

Before of the installation it is necessary to calculate the safety distance in order to allow the stop of the machine before the operator enter in the dangerous area ( as described in EN 999 and ISO 13855 ).

### Definitions:

- S** safety distance in mm
- T1** response time of machine in msec
- T2** response time of curtain in msec  
(see TX / RX label)
- d** resolution of the system in mm

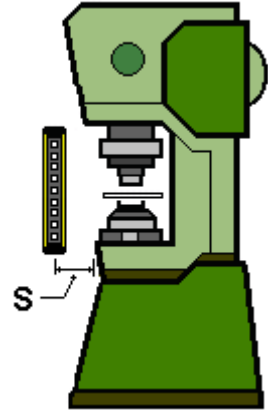

### Vertical installation

#### Models with resolution up to 40 mm

The following formula is valid for a distance S included between 100 and 500 mm :

$$S = 2 (T1 + T2) + 8 (d - 14)$$

If **S** results more of 500 mm, use the following formula :

$$S = 1,6 (T1 + T2) + 8 (d-14)$$

#### Models with resolution more than 40 and up to 90 mm

$$S = 1,6 (T1 + T2) + 850$$

The highest beam must be placed at a minimum height of 900 mm from the installation plane of the machine, while the inferior beam must be at a height less than 300 mm

#### Models with resolution more than 90 mm

$$S = 1,6 (T1 + T2) + 1.200$$

**For applications on packaging machines (e.g. palletizer ) must be complied with the instructions provided in the standard EN415-4.**

## MINIMUM DISTANCE TO AVOID REFLECTIONS

The beam angle of optic and alignment tolerance for emitter and receiver is 5 degrees. Since reflective surfaces near the detection area can cause reflections and therefore non-detection of an object, a minimum distance **A** to the optical axis, should be observed according to the following formula:

$$A = 44 L \quad \text{where } A \text{ is in mm, } L \text{ is in m}$$

**A** should never be less than 131 mm

To verify the above, after the installation of the light curtain, is necessary to pass the test rod through the detection zone, near the emitter, the receiver and in the middle of the detection zone, verifying that :

If selected the automatic restart      the LED OS OFF should remain always ON;  
 If selected the manual restart          the LED BMS should remain always OFF.

If the indication are not as described above, there is a hole in the detection zone due to reflection. Modify the position of the barrier in order to avoid the reflection.

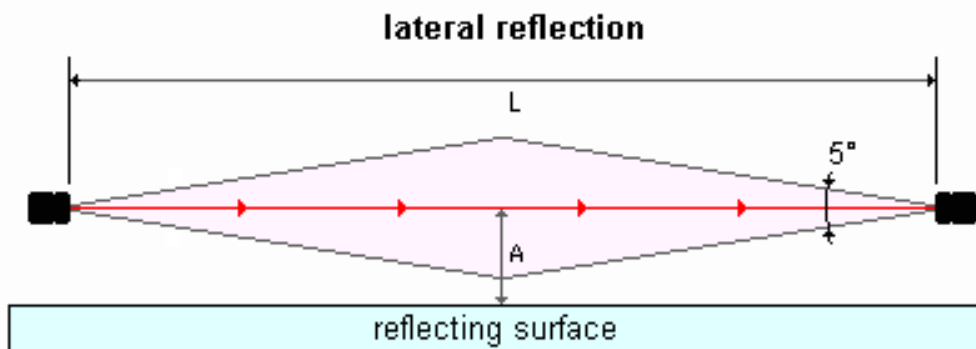
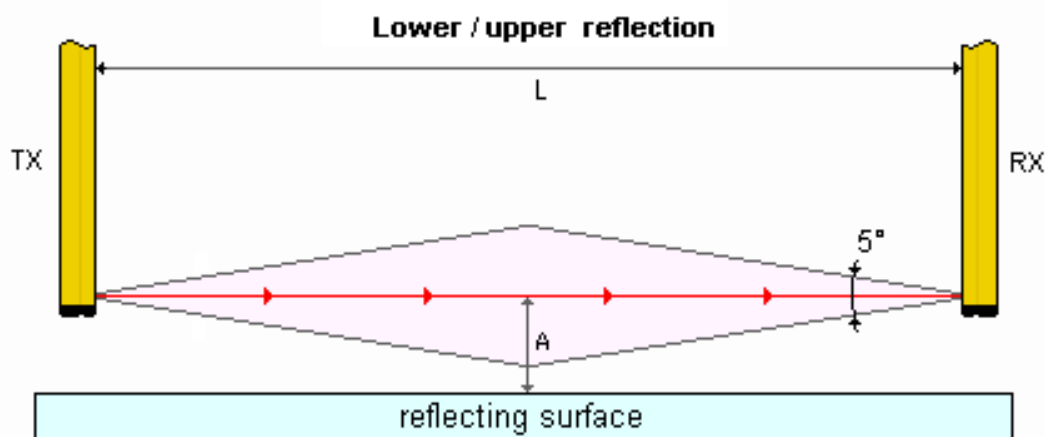



### MECHANICAL ASSEMBLY

During the installation it is necessary to verify the right position of emitter and receiver in order to check that they are in the same plane and axis as shown on the following drawings.

**SIDE VIEW:**

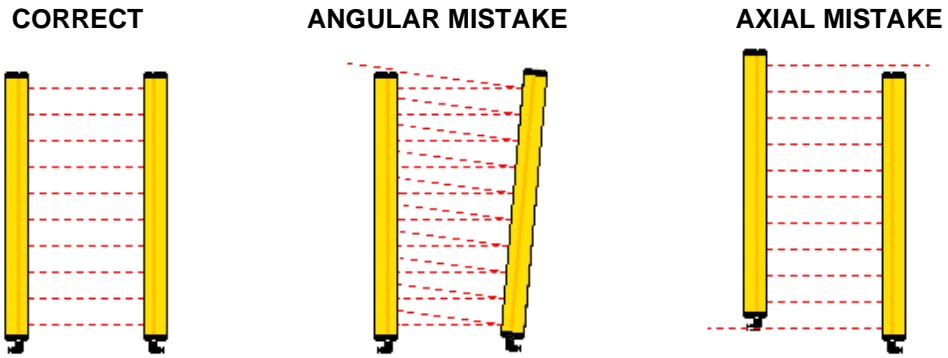

**TOP VIEW:**

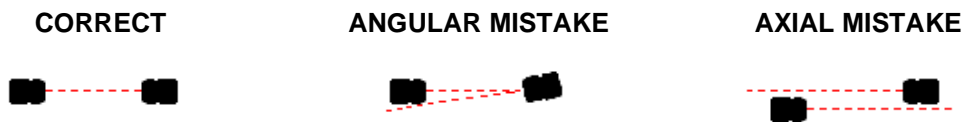

### GROUPING OF LIGHT CURTAINS

Suggestions to avoid interference between light curtains assembled in line in case of long distances or protected machines installed in series:

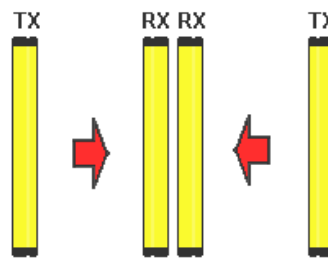

The light curtain can work on vertical position or upside-down. Don't turn the transmitter in the opposite direction of the receiver, it changes the protected field.

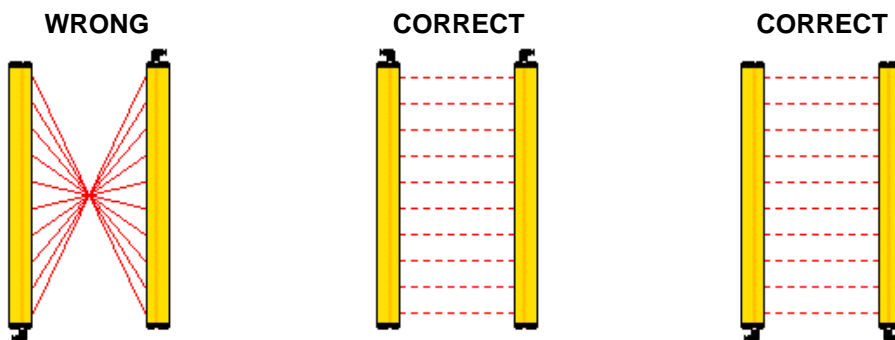

## OVERVIEW KEEPER MODELS AND FUNCTIONS

The peculiar feature is the predisposition for MUTING sensors. The sensors can be housed in movable arms attached to the vertical barrier, with adjustable settings during installation (xxM series). Alternatively, only the vertical barriers can be provided with the predisposition for connecting external muting sensors chosen by the customer (xxi series).

TPM, TXM, LPM, LXM

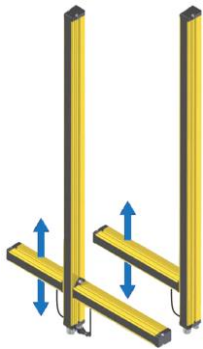

TPI, TXi, LPI, LXi



May be provided in the configuration **T** for the control of entry and exit, or **L** for the exit control. The beams sensors can be configured in **parallel** or **crossed** configuration.

In the version with **parallel** MUTING sensors, the muting is active when the correct sequence of interruption of the beams sensors is performed.

The maximum distance between TX and RX is 5m.

In the T version the material being processed can interrupt the muting sensors in any direction of the movement.

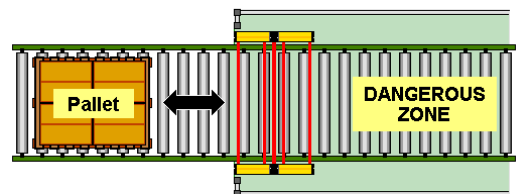

In the version with **crossed** muting sensors, the muting is active when the beams muting sensors are interrupted simultaneous.

The maximum distance between TX and RX is 2.5 m.

The material being processed must interrupt the muting sensors in the central area.

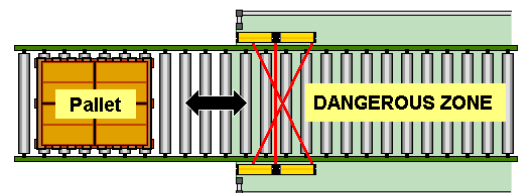

In the T version the material being processed can interrupt the muting sensors in any direction of the movement.

### LIST OF MODELS AND CHARACTERISTICS

The images describe the main parameters considered in the selection of light curtain, in the following pages are shown the complete list of barriers "KEEPER" series.

**Total height.** To estimate the total height of the barrier, check the column H ( barrier height ) in table below and add the connector height shown in the figure below.

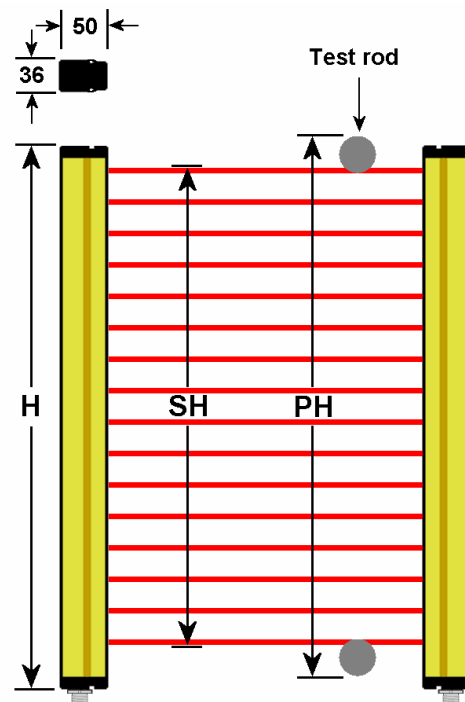

#### Minimum connectors space

It is necessary to provide a minimum space for the connector, refer to figure below.

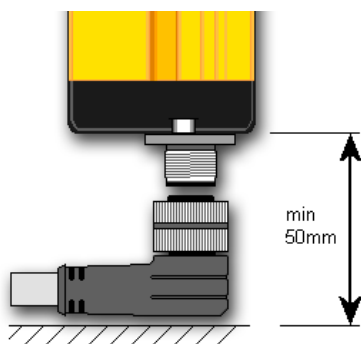

M12 angle

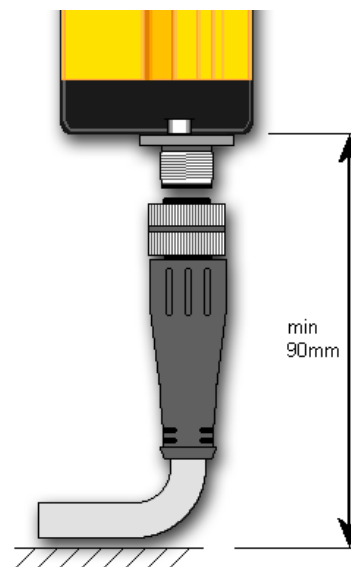

M12 straight

**Special size.** If the standard barriers don't satisfy the customer application, our technical office will evaluate the possibility to produce a custom model.

**BARRIER CODE**

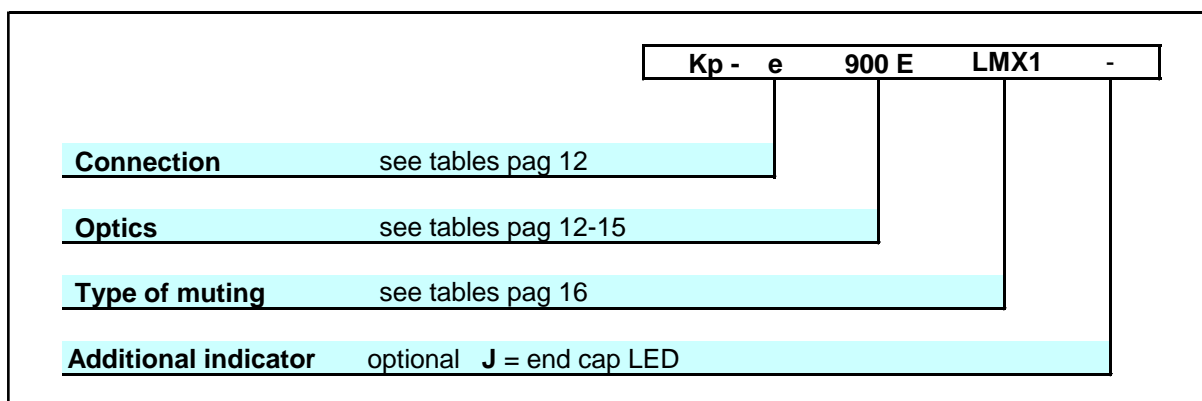

Connection	Function										RX connectors	
	TEST	RES	EDM	GOVR	M-S	M 0-1	M-F	M-E	MT-0	MT-1	M12 5 Poli	M12 8 Poli
KP-e ... -	•	•	•	•	•	•					•	•
KP-e1 ... -	•	•	•	•	•		•		•		•	•
KP-e2 ... -	•	•	•	•	•			•	•		•	•
KP-e3 ... -	•	•	•	•	•		•		•	•	•	•

- TEST      Test input on the transmitter unit;
- RES      Automatic and manual reset;
- EDM      External contactors control;
- GOVR     Guard override for recovery in case of muting function failure;
- M-S      MUTE-S, active muting lamp output;
- M 0-1    MUTE-0-1 inputs for external muting sensors;
- M-F      MUTE-F, output signalling vertical barrier interrupted during the MUTING function.
- M-E      MUTE-E, input for muting enable.
- MT 0     TIME-0 selection of the maximum duration of the MUTING function (1 minute, 90 minutes);
- MT 1     TIME-1 selection of the maximum duration of the MUTING function (1 minute, 90 minutes, 24 hours)

**Optics**

Optic	Resolution	Min range	max X range	max P range	max I range
-- A	14 mm	0.5 m	2.5 m	5 m	6 m
-- B	30 mm	0.5 m	2.5 m	5 m	15 m
-- C	55 mm	0.5 m	2.5 m	5 m	15 m
-- D	125 mm	0.5 m	2.5 m	5 m	15 m
-- E	306 mm	0.5 m	2.5 m	5 m	15 m

-- Detection height code

**Models / optics**

Resolution 14mm Range 0,5 - 6m Optical Code "A"								
Model	N° of beams	Protected Height PH ( mm )	Sensitive Height SH ( mm )	Barrier Height H ( mm )	Weight (Tx+RX) ( Kg )	Response Time ( ms )	Mtff ( years )	PL
KP - x - 240 A - yyyy	24	254	234	330	1.2	6	100	e
KP - x - 360 A - yyyy	36	374	354	450	1.6	11	100	e
KP - x - 480 A - yyyy	48	494	474	570	2.0	11	100	e
KP - x - 600 A - yyyy	60	614	594	690	2.4	11	100	e
KP - x - 700 A - yyyy	72	734	714	810	2.8	16	84.06	e
KP - x - 850 A - yyyy	84	854	834	930	3.2	16	76.09	e
KP - x - 950 A - yyyy	96	974	954	1050	3.6	16	69.51	e
KP - x - 1100 A - yyyy	108	1094	1074	1170	4.0	16	63.97	e

Resolution 30mm Range 0,5 - 15m Optical code "B"								
Model	N° of beams	Protected Height PH ( mm )	Sensitive Height SH ( mm )	Barrier Height H ( mm )	Weight (Tx+RX) ( Kg )	Response Time ( ms )	Mtff ( years )	PL
KP - x - 300 B - yyyy	12	318	270	372	1.3	6	100	e
KP - x - 450 B - yyyy	18	462	414	516	1.7	6	100	e
KP - x - 600 B - yyyy	24	606	558	660	2.1	6	100	e
KP - x - 750 B - yyyy	30	750	702	804	2.4	11	100	e
KP - x - 900 B - yyyy	36	894	846	948	2.8	11	100	e
KP - x - 1050 B - yyyy	42	1038	990	1092	3.2	11	100	e
KP - x - 1200 B - yyyy	48	1182	1134	1236	3.6	11	100	e
KP - x - 1350 B - yyyy	54	1326	1278	1380	4.1	11	100	e
KP - x - 1500 B - yyyy	60	1470	1422	1524	4.5	11	100	e
KP - x - 1650 B - yyyy	66	1614	1566	1668	4.9	11	100	e
KP - x - 1800 B - yyyy	72	1758	1710	1812	5.3	16	100	e
KP - x - 1950 B - yyyy	78	1902	1854	1956	5.7	16	100	e
KP - x - 2100 B - yyyy	84	2046	1998	2100	6.1	16	100	e
KP - x - 2200 B - yyyy	90	2190	2142	2244	6.5	16	100	e
KP - x - 2300 B - yyyy	96	2334	2286	2388	6.9	16	100	e
KP - x - 2450 B - yyyy	102	2478	2430	2532	7.3	16	100	e
KP - x - 2650 B - yyyy	108	2622	2574	2676	7.7	16	99.18	e

x = type of connection    yyyy = type of muting  
for details see pag 10 - 12

Resolution 55mm Range 0,5 - 15m Optical code "C"								
Model	N° of beams	Protected Height PH ( mm )	Sensitive Height SH ( mm )	Barrier Height H ( mm )	Weight (Tx+RX) ( Kg )	Response Time ( ms )	Mtff ( years )	PL
KP - x - 300 C - yyyy	6	344	246	372	1.3	6	100	e
KP - x - 450 C - yyyy	9	488	390	516	1.7	6	100	e
KP - x - 600 C - yyyy	12	632	534	660	2.1	6	100	e
KP - x - 750 C - yyyy	15	776	678	804	2.5	6	100	e
KP - x - 900 C - yyyy	18	920	822	948	2.9	6	100	e
KP - x - 1050 C - yyyy	21	1064	966	1092	3.3	6	100	e
KP - x - 1200 C - yyyy	24	1208	1110	1236	3.7	6	100	e
KP - x - 1350 C - yyyy	27	1352	1254	1380	4.1	11	100	e
KP - x - 1500 C - yyyy	30	1496	1398	1524	4.5	11	100	e
KP - x - 1650 C - yyyy	33	1640	1542	1668	4.9	11	100	e
KP - x - 1800 C - yyyy	36	1784	1686	1812	5.3	11	100	e
KP - x - 1950 C - yyyy	39	1928	1830	1956	5.6	11	100	e
KP - x - 2100 C - yyyy	42	2072	1974	2100	6.0	11	100	e
KP - x - 2200 C - yyyy	45	2216	2118	2244	6.4	11	100	e
KP - x - 2300 C - yyyy	48	2360	2262	2388	6.9	11	100	e
KP - x - 2450 C - yyyy	51	2504	2406	2532	7.3	11	100	e
KP - x - 2650 C - yyyy	54	2648	2550	2676	7.7	11	100	e
KP - x - 2750 C - yyyy	57	2792	2694	2820	8.1	11	100	e
KP - x - 2900 C - yyyy	60	2936	2838	2964	8.5	11	100	e
KP - x - 3000 C - yyyy	63	3080	2982	3108	8.9	11	100	e

x = type of connection      yyyy = type of muting  
 for details see pag 10 - 12

Resolution 125mm Range 0,5 - 15m Optical code "D"							
Model	N° of beams	Sensitive Height SH ( mm )	Barrier Height H ( mm )	Weight (Tx+RX) ( Kg )	Response Time ( ms )	Mtff ( years )	PL
KP - x - 350 D - yyyy	4	366	468	1.6	6	100	e
KP - x - 600 D - yyyy	6	606	708	2.8	6	100	e
KP - x - 850 D - yyyy	8	846	948	3.2	6	100	e
KP - x - 1050 D - yyyy	10	1086	1188	4.2	6	100	e
KP - x - 1350 D - yyyy	12	1326	1428	4.8	6	100	e
KP - x - 1550 D - yyyy	14	1566	1668	5.4	6	100	e
KP - x - 1800 D - yyyy	16	1806	1908	6.0	6	100	e
KP - x - 2050 D - yyyy	18	2046	2148	6.6	6	100	e
KP - x - 2250 D - yyyy	20	2286	2388	7.2	6	100	e
KP - x - 2550 D - yyyy	22	2526	2628	7.8	6	100	e
KP - x - 2750 D - yyyy	24	2766	2868	8.4	6	100	e
KP - x - 3050 D - yyyy	26	3006	3108	9.0	11	100	e

Resolution 306mm Range 0,5 - 15m Optical code "E"							
Model	N° of beams	Sensitive Height SH ( mm )	Barrier Height H ( mm )	Weight (Tx+RX) ( Kg )	Response Time ( ms )	Mtff ( years )	PL
KP -x - 300 E - yyyy	2	306	458	1.5	6	100	e
KP -x - 650 E - yyyy	3	606	758	1.9	6	100	e
KP -x - 900 E - yyyy	4	906	1058	3.0	6	100	e
KP -x - 1200 E - yyyy	5	1206	1358	4.1	6	100	e
KP -x - 1550 E - yyyy	6	1506	1658	5.2	6	100	e
KP -x - 1800 E - yyyy	7	1806	1958	6.3	6	100	e
KP -x - 2250 E - yyyy	8	2106	2258	7.4	6	100	e
KP -x - 2400 E - yyyy	9	2406	2558	8.5	6	100	e
KP -x - 2750 E - yyyy	10	2706	2858	9.6	6	100	e
KP -x - 3000 E - yyyy	11	3006	3158	10.7	6	100	e

x = type of connection    yyyy = type of muting  
for details see pag 10 - 12

**NOTE**

The weight of the barrier is referred only at the vertical series **TPi, TXi, LPi, LXi**. without arms.  
For the weight of the other model add the weight of the arms ad follow.

ARM type	Total weight of the TX + RX arms
LX / LP	0,8 Kg
TX / TP	1,6 Kg

Braccetti muting

Muting	Integrated muting arms
LXM 1	Muting L, with 2 cross beams arms, receiver right
LXM 2	Muting L, with 2 cross beams arms, receiver left
LPM 1	Muting L, with 2 parallel beams arms, receiver right
LPM 2	Muting L, with 2 parallel beams arms, receiver left
TXM 1	Muting T, with 2 cross beams arms, receiver right
TXM 2	Muting T, with 2 cross beams arms, receiver left
TPM 3	Muting T, with 4 parallel beams

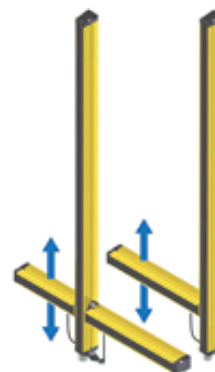

Muting	External muting arms
LXi 3	Muting L, for 2 external cross sensors
LPi 3	Muting L, for 2 external parallel sensors
TXi 3	Muting T, for 2 external cross sensors
TPi 3	Muting T, for 4 external parallel sensors

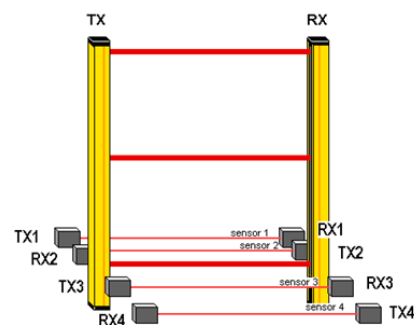

Left and right receiver refer to the position of the receiver while observing the protected area from outside.

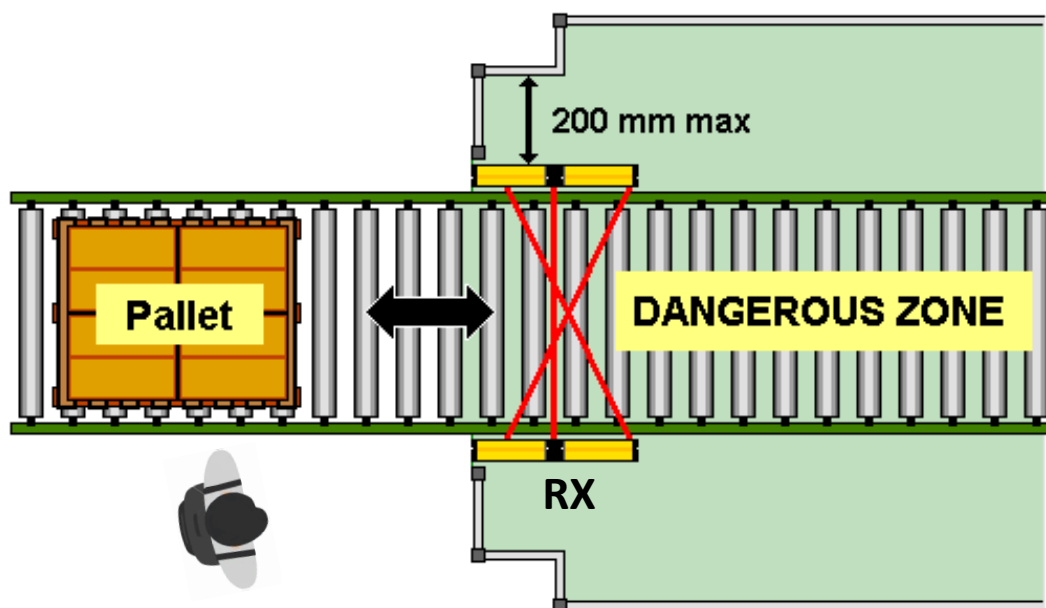

Example of installation with RX right



**OVERALL DIMENSIONS MUTING ARMS**

Keeper TP  
4 parallel muting beams

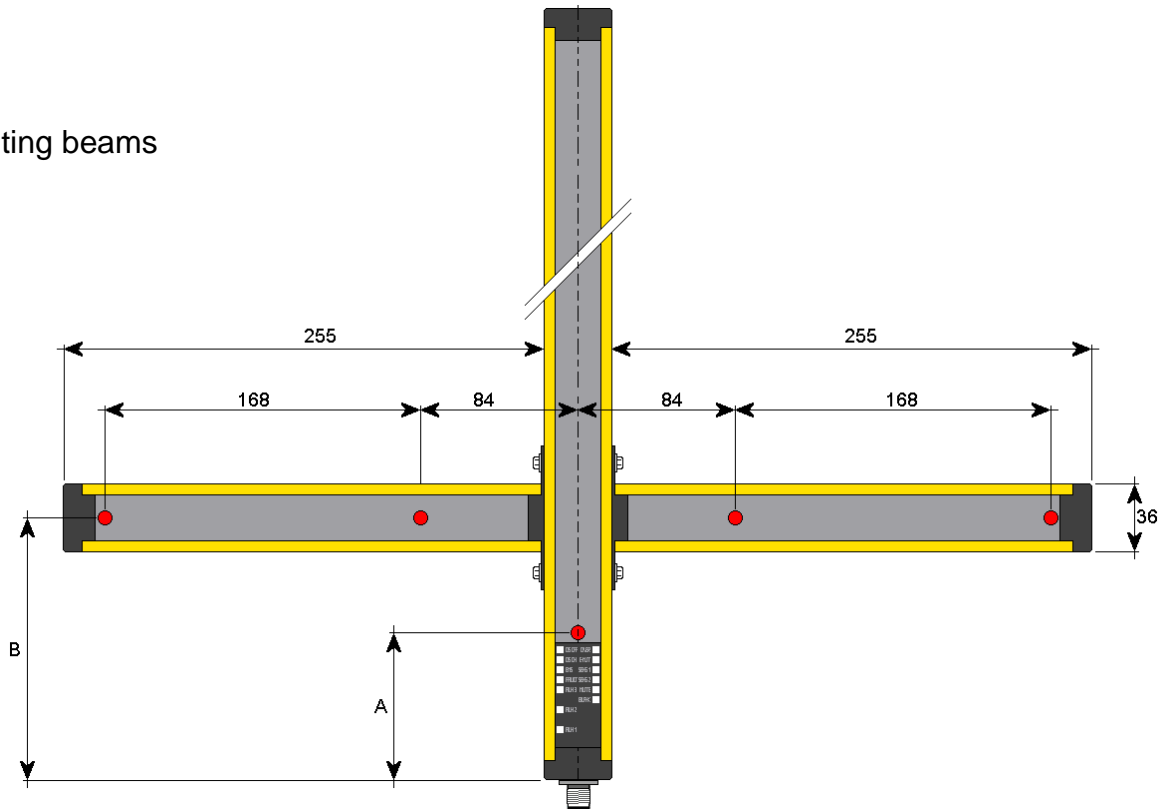

Keeper TX  
2 cross muting beams

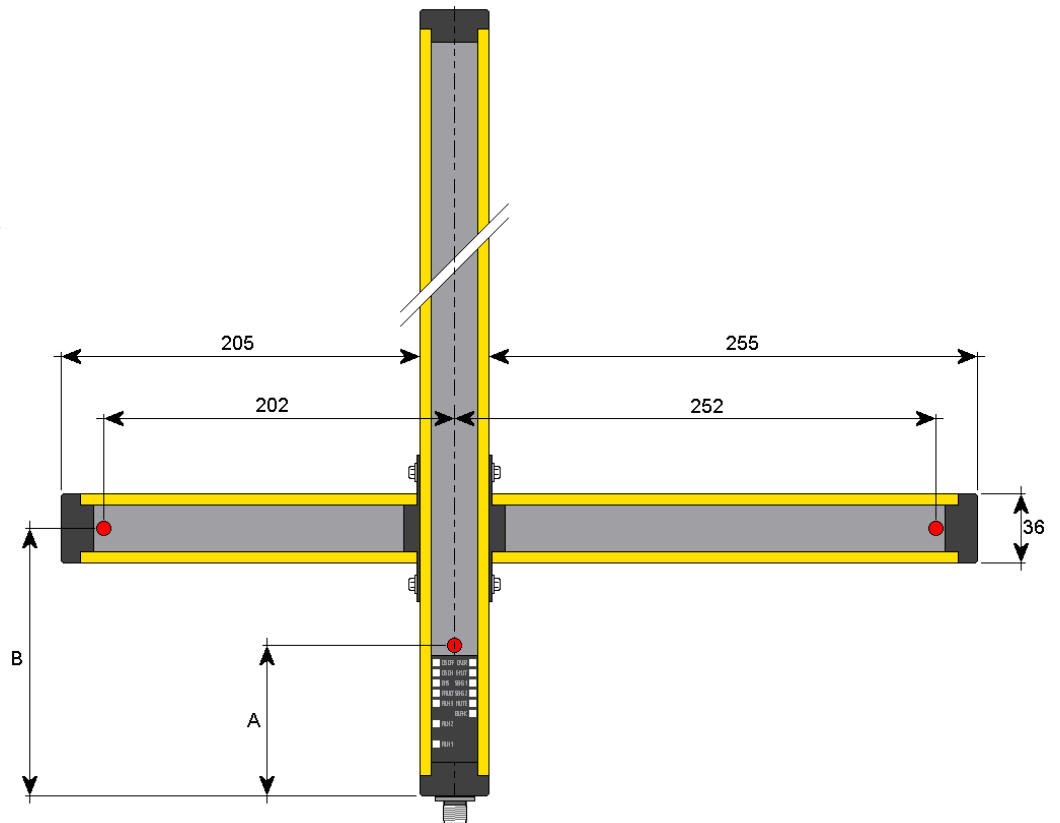

Keeper **LP / LX**  
2 parallel / cross muting beams

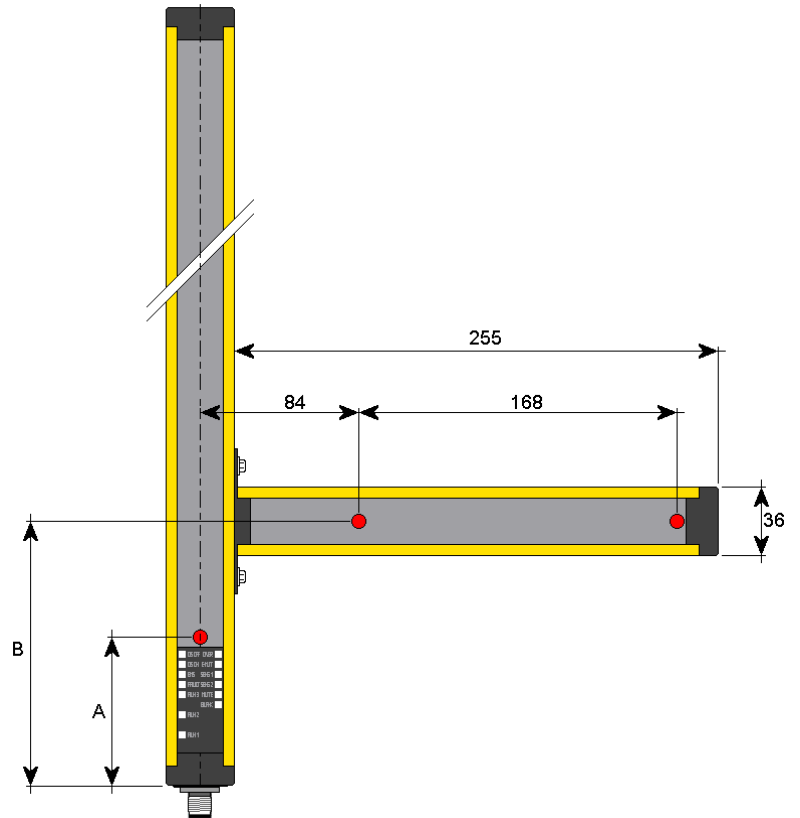

**A** Position of the first beam of vertical barrier :

Optic	Resolution	A
-- A	14 mm	76 mm
-- B	30 mm	82 mm
-- C	55 mm	82 mm
-- D	125 mm	82 mm
-- E	306 mm	106 mm

**B** position of the muting beams arms

Version mobile arms

**B min** = 55 mm

**B max** = 230 mm

( the **B** dimensions can be changed on customer request )

The connector dimension is reported in page 11.

## WIRING CONNECTION

### Warning on connection cables

- 1 - Use cables with section of 1 mm<sup>2</sup> for length connection more than 50 m.
- 2 - The units TX / RX shall be connect to the ground ( PE ).
- 3 - All the cables shall follow different way from those of power.
- 4 - The power of the barrier should be separated from that of equipment dedicated to the control of power equipment, such as inverters.
- 5 - If there is the possibility to damage the cables, take care to protect them against crushing or cutting.
- 6 - The cables should be shielded type the shield should be connected to ground ( PE ).

### KP Emitter connections

Emitter		KP - ... -				
Pin N	Wire color	Function	Description	Type	Level	
M12 4 poles						
1	Brown	+24V	Positive power supply	IN	+24 Vdc +/- 10%	0,5A
2	White	TEST	TEST signal	IN	0 - 24 Vdc	10 mA
3	Blue	GND	0V power supply	IN	0V	
4	Black	PE	Ground	-	-	

Example of connection

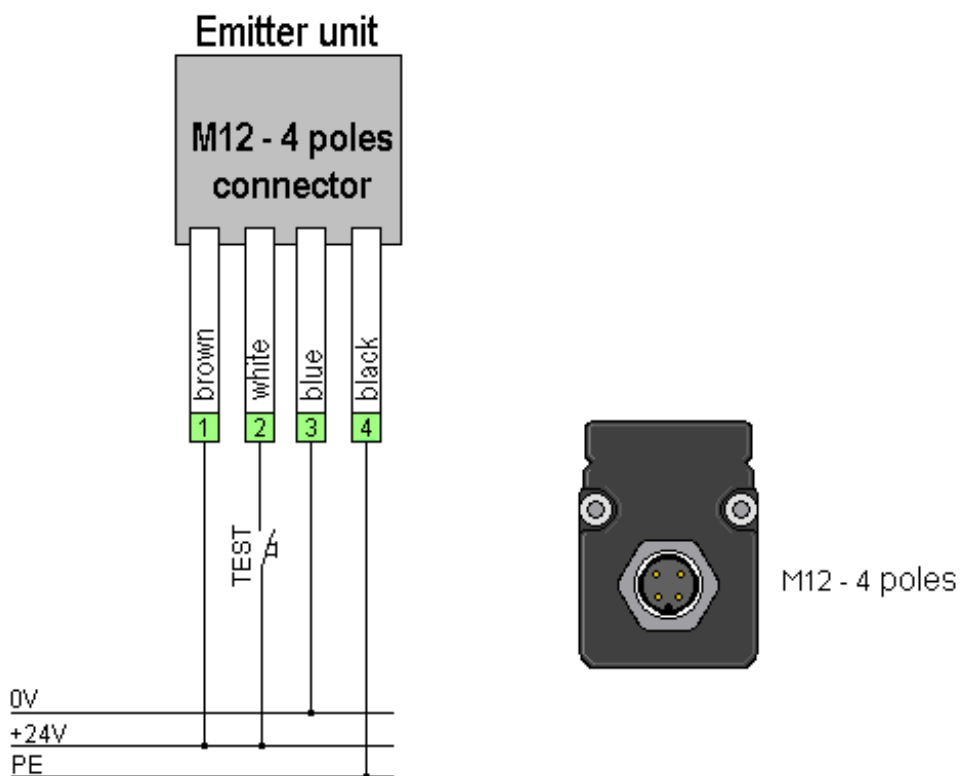

**KP- e RECEIVER CONNECTIONS**

Receiver KP-e - ... Reset + Edm + external muting						
Pin N	Wire color	Function	Description	Type	Level	
M12 8 poles						
1	White	OSSD-0	Static output safety 0	OUT	0 - 24 Vdc	0,5A max
2	Brown	+24V	Positive power supply	IN	+24 Vdc +/- 10%	1A
3	Green	START ENABLE	Selection of manual or automatic reset	IN	0 - 24 Vdc	10mA
4	Yellow	START	Input of external RESET	IN	0 - 24 Vdc	10mA
5	Grey	OSSD-1	Static output safety 1	OUT	0 - 24 Vdc	0,5A max
6	Pink	EDM	External device monitor input	IN	0 - 24 Vdc	10mA
7	Blue	GND	0V power supply	IN	0V	
8	Red	PE	Ground	-	-	
M12 5 poles						
1	Brown	GOVR-0	Guard override input 0, bypass of the muting function	IN	0 - 24 Vdc	10mA
2	White	GOVR-1	Guard override input1, bypass of the muting function	IN	0 - 24 Vdc	10mA
3	Blue	MUTE-0	External muting 0 input	IN	0 - 24 Vdc	10mA
4	Black	MUTE-1	External muting 1 input	IN	0 - 24 Vdc	10mA
5	Grey	MUTE-S	Muting lamp output	OUT	0 - 24 Vdc	0,5A max

Example of connections

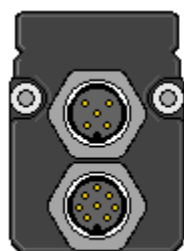
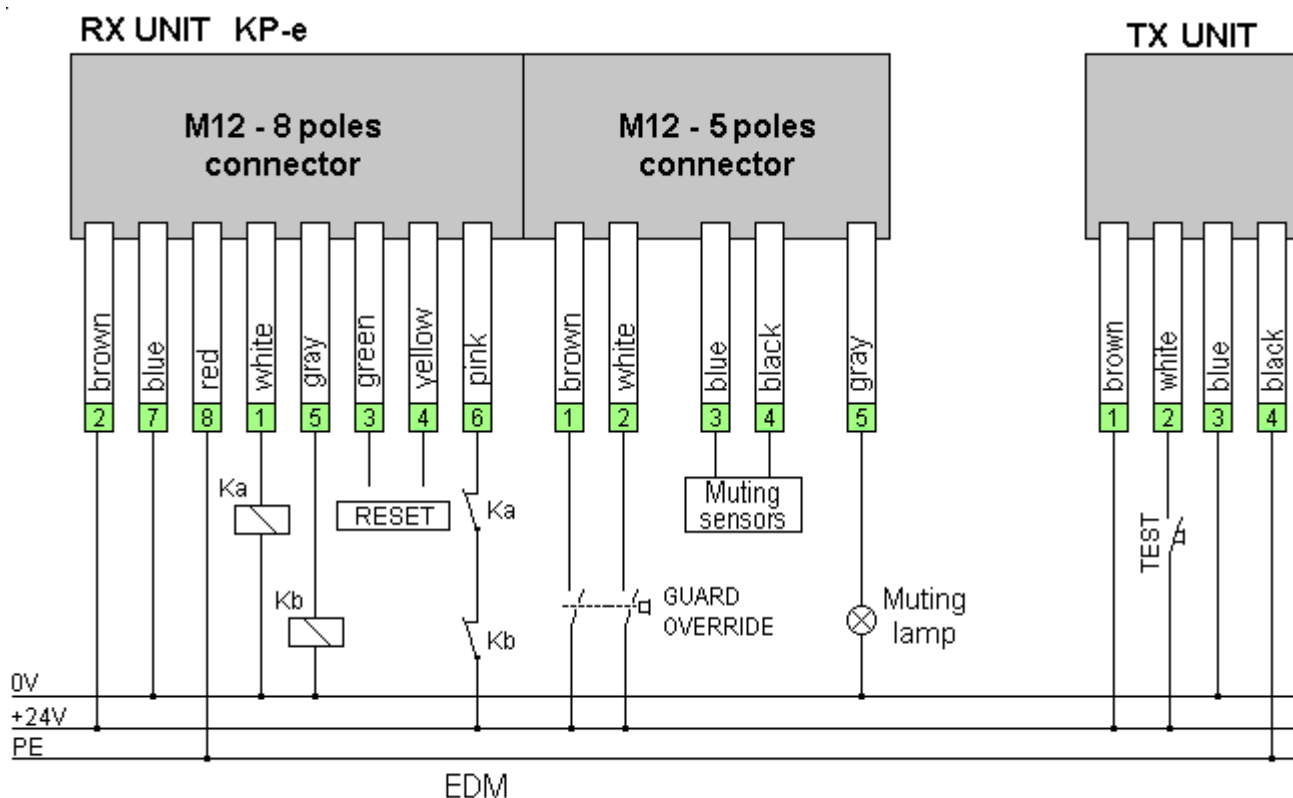

M12 5 poles

M12 8 poles

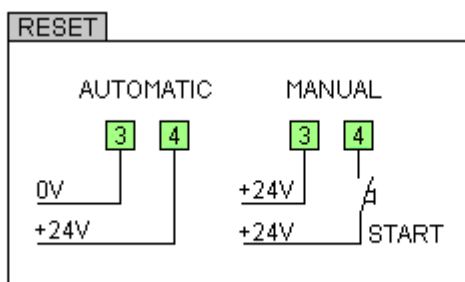

KP- e1 RECEIVER CONNECTIONS

Receiver KP-e1 - ... Reset + Edm + Muting Time + Mute-F						
Pin N	Wire color	Function	Description	Type	Level	
M12 8 poles						
1	White	OSSD-0	Static output safety 0	OUT	0 - 24 Vdc	0,5 A max
2	Brown	+24V	Positive power supply	IN	+24 Vdc +/- 10%	2A
3	Green	START ENABLE	Selection of manual or automatic reset	IN	0 - 24 Vdc	10 mA
4	Yellow	START	Input of external RESET	IN	0 - 24 Vdc	10 mA
5	Grey	OSSD-1	Static output safety 1	OUT	0 - 24 Vdc	0,5 A max
6	Pink	EDM	External device monitor input	IN	0 - 24 Vdc	10 mA
7	Blue	GND	0V power supply	IN	0V	
8	Red	PE	Ground	-	-	
M12 5 poles						
1	Brown	GOVR-0	Guard override input 0, bypass of the muting function	IN	0 - 24 Vdc	10 mA
2	White	GOVR-1	Guard override input1, bypass of the muting function	IN	0 - 24 Vdc	10 mA
3	Blue	TIME-0	Input 0 muting time setup	IN	0 - 24 Vdc	10 mA
4	Black	MUTE-F	Output for indication of barrier beam interrupted when MUTING function is activated	OUT	0 - 24 Vdc	0,5 A max
5	Grey	MUTE-S	Muting lamp output	OUT	0 - 24 Vdc	0,5 A max

Example of connections

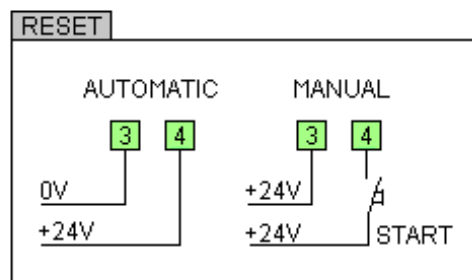
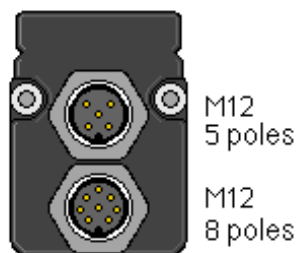
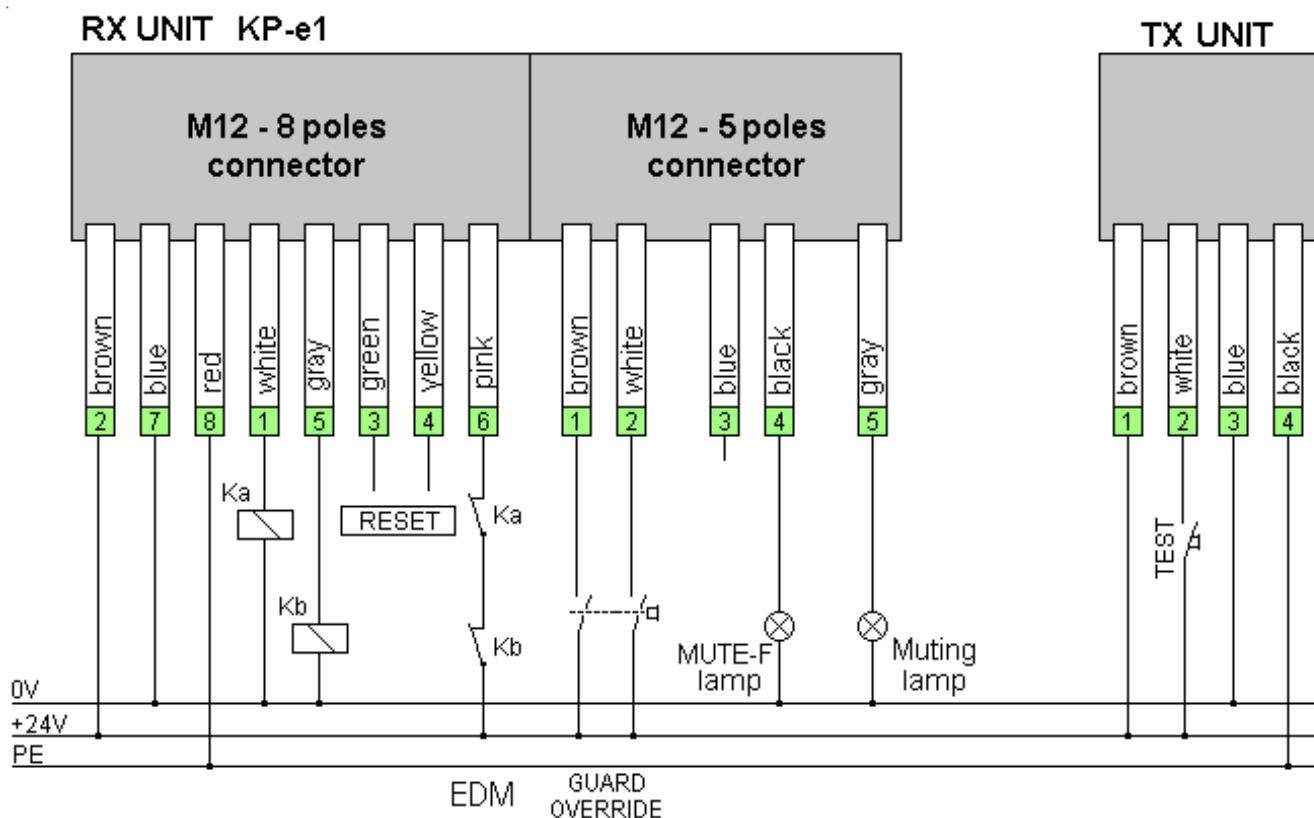

SETTING OF MUTING TIME	
TIME - 0	Maximum duration of muting time
0V	1 minute
+24V	90 minutes

KP- e2 RECEIVER CONNECTIONS

Receiver KP-e2 - ... Reset + Edm + Muting Time + Mute-E						
Pin N	Wire color	Function	Description	Type	Level	
M12 8 poles						
1	White	OSSD-0	Static output safety 0	OUT	0 - 24 Vdc	0,5 A max
2	Brown	+24V	Positive power supply	IN	+24 Vdc +/- 10%	2 A
3	Green	START ENABLE	Selection of manual or automatic reset	IN	0 - 24 Vdc	10 mA
4	Yellow	START	Input of external RESET	IN	0 - 24 Vdc	10 mA
5	Grey	OSSD-1	Static output safety 1	OUT	0 - 24 Vdc	0,5 A max
6	Pink	EDM	External device monitor input	IN	0 - 24 Vdc	10 mA
7	Blue	GND	0V power supply	IN	0V	
8	Red	PE	Ground	-	-	
M12 5 poles						
1	Brown	GOVR-0	Guard override input 0, bypass of the muting function	IN	0 - 24 Vdc	10 mA
2	White	GOVR-1	Guard override input1, bypass of the muting function	IN	0 - 24 Vdc	10 mA
3	Blue	TIME-0	Input 0 muting time setup	IN	0 - 24 Vdc	10 mA
4	Black	MUTE-E	Input enabling MUTING function	IN	0 - 24 Vdc	10 mA
5	Grey	MUTE-S	Muting lamp output	OUT	0 - 24 Vdc	0,5 A max

Example of connections

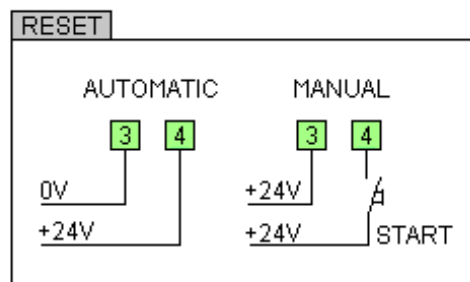
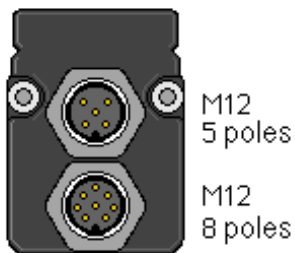
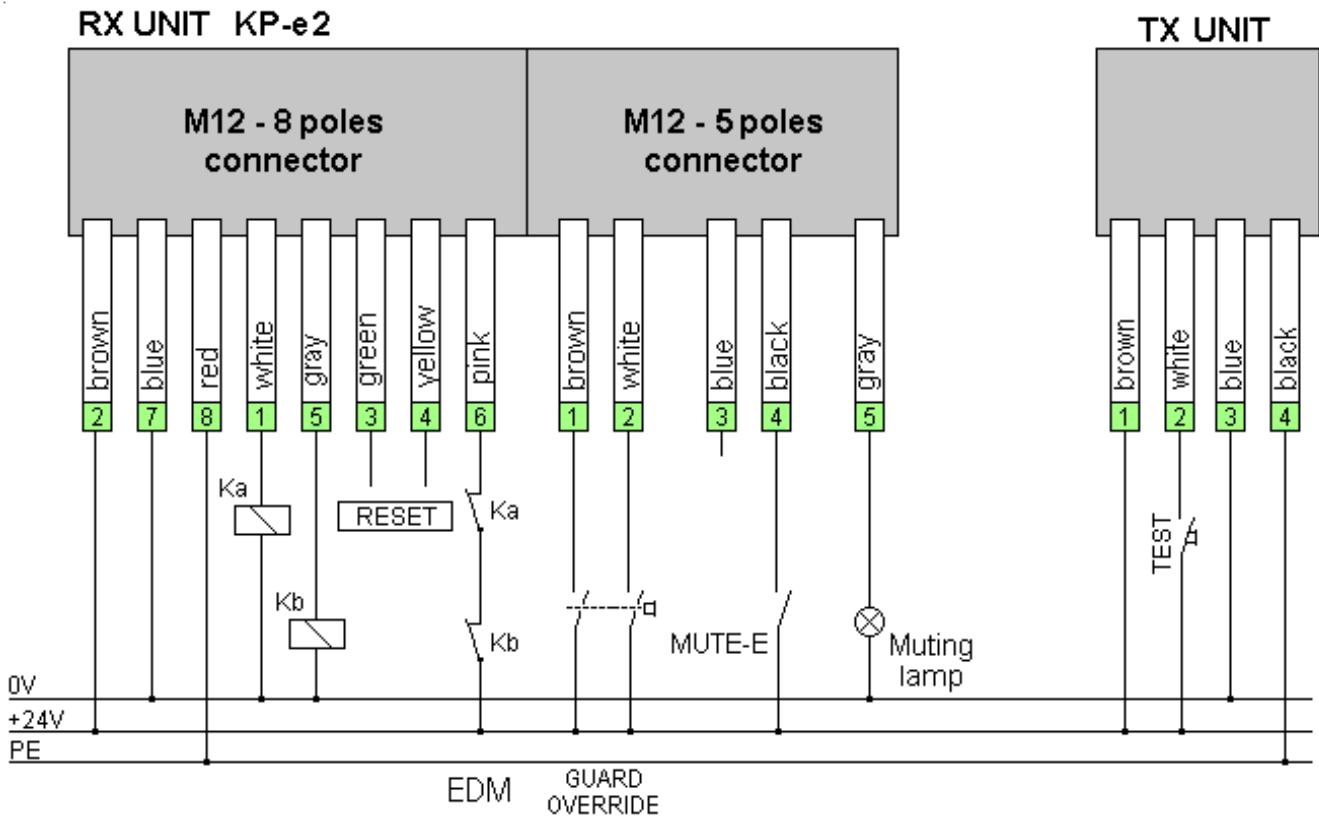

SETTING OF MUTING TIME	
TIME - 0	Maximum duration of muting time
0V	1 minute
+24V	90 minutes

KP- e3 RECEIVER CONNECTIONS

Receiver KP-e3 - ... Reset + Edm + Muting Time						
Pin N	Wire color	Function	Description	Type	Level	
M12 8 poles						
1	White	OSSD-0	Static output safety 0	OUT	0 - 24 Vdc	0,5 A max
2	Brown	+24V	Positive power supply	IN	+24 Vdc +/- 10%	2 A
3	Green	START ENABLE	Selection of manual or automatic reset	IN	0 - 24 Vdc	10 mA
4	Yellow	START	Input of external RESET	IN	0 - 24 Vdc	10 mA
5	Grey	OSSD-1	Static output safety 1	OUT	0 - 24 Vdc	0,5 A max
6	Pink	EDM	External device monitor input	IN	0 - 24 Vdc	10 mA
7	Blue	GND	0V power supply	IN	0V	
8	Red	PE	Ground	-	-	
M12 5 poles						
1	Brown	GOVR-0	Guard override input 0, bypass of the muting function	IN	0 - 24 Vdc	10 mA
2	White	GOVR-1	Guard override input1, bypass of the muting function	IN	0 - 24 Vdc	10 mA
3	Blue	TIME-0	Input 0 muting time setup	IN	0 - 24 Vdc	10 mA
4	Black	TIME-1	Input 1 muting time setup	IN	0 - 24 Vdc	10 mA
5	Grey	MUTE-S	Muting lamp output	OUT	0 - 24 Vdc	0,5A max

Example of connections

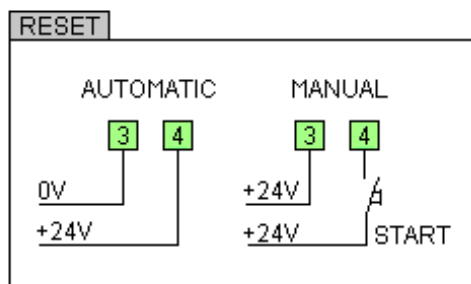
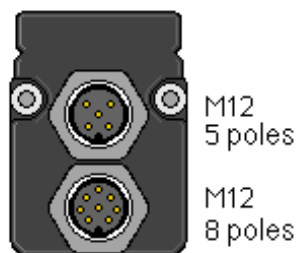
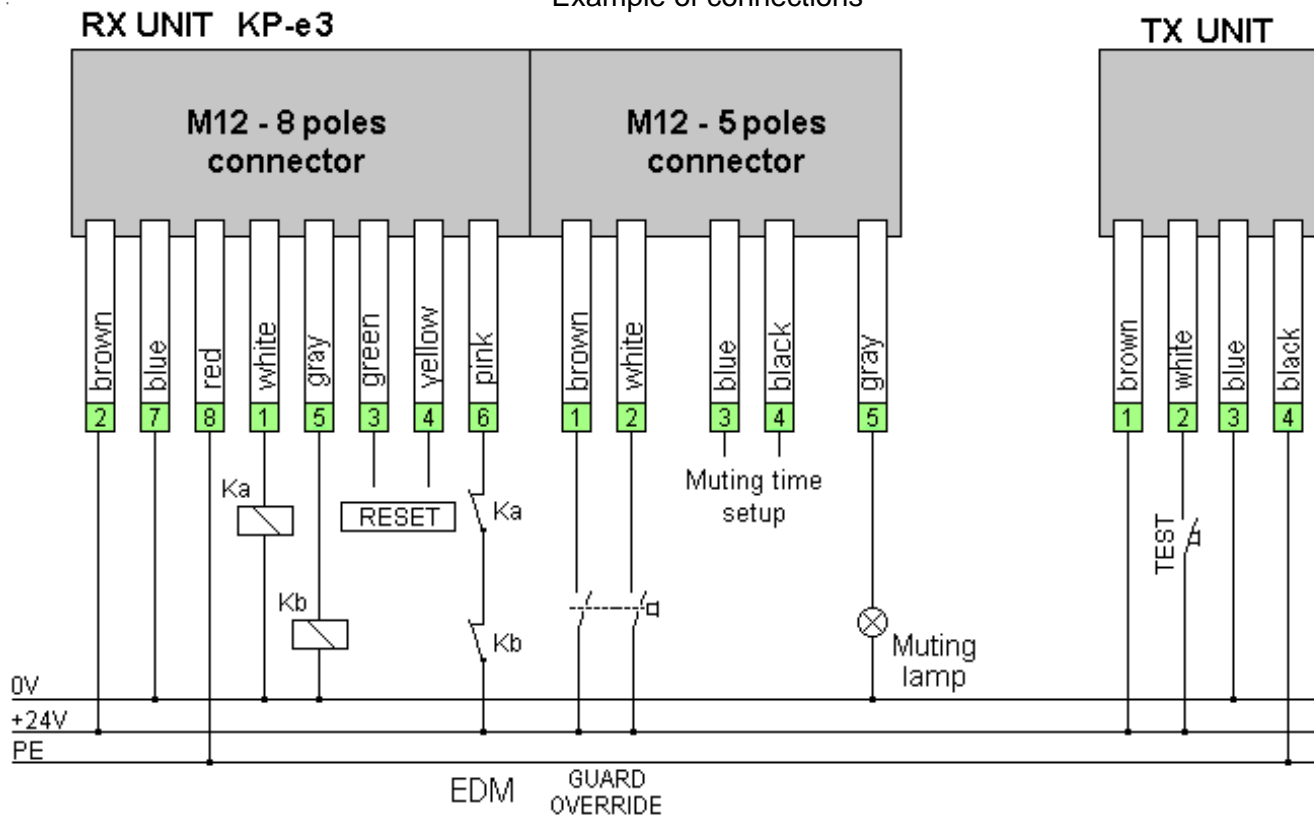

SETTING OF MUTING TIME		
TIME - 0	TIME - 1	Maximum duration of muting time
0V	0V	1 minute
0V	+24V	24 hours
+24V	0V	90 minutes
+24V	+24V	1 minute

## EXTERNAL CONTACTORS CONNECTION

The diagram below shows the connection of the external contactors for increase the number of contacts or the necessary current to the load and the connection contacts of the feedback signal to the EDM (pink wire).

The voltage supplied by the OSSD output is 24 Vdc with a maximum current of 0.5 A. Select the external contactors on the basis of these values .

In the example below, a KEEPER model “ e “with automatic restart, is connected to Ka and Kb contactors.

The normally closed contacts of external contactors are connected in series, with the voltage of +24 Vdc and the EDM input (pink wire) of the light curtain.

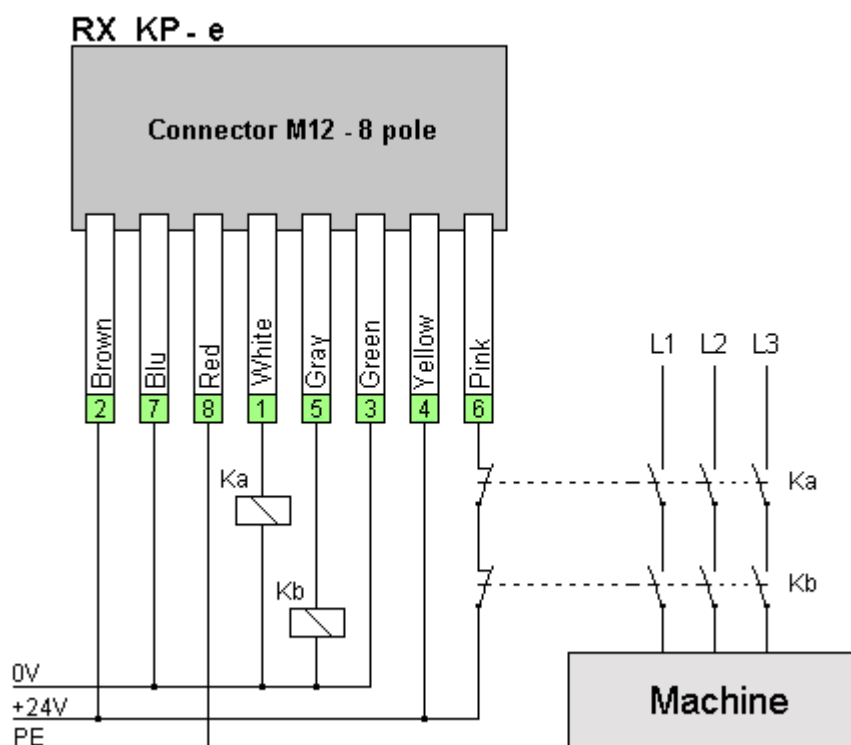



## EMITTER CONNECTIONS AND FUNCTIONS

<b>+24 Vdc</b>	+24 Vdc Power supply
----------------	----------------------

Connect to +24 Vdc  $\pm 10\%$  1 A power supply.

The current of 1A is the supply current for all type of KEEPER light curtains.

<b>0 V</b>	0 Vdc Power supply
------------	--------------------

Connect to 0 Vdc of 24 Vdc power supply.

<b>PE</b>	Protective Earth
-----------	------------------

Connect to the ground of machine.

<b>TEST</b>	Input for TEST
-------------	----------------

This signal simulates the interruption of the beams to check the safety chain.

The TEST is active when connected to +24 Vdc.

During the test, OSSD0 and OSSD1 are in OFF state and the POWER / TEST indicator blinks.

If connected to 0V or not connected the test is not active, the POWER / TEST indicator is OFF.

## RECEIVER CONNECTIONS AND FUNCTIONS

Some of the following functions can be present or not, depending of the model ordered.

### Power supply

<b>+24 Vdc</b>	+24 Vdc Power supply
----------------	----------------------

Connect to +24 Vdc  $\pm 10\%$  2 A power supply.

The current of 1A is the supply current for the KEEPER light curtains.

To calculate the total current is necessary to include:

- OSSD0 and OSSD1 absorbed current ( max 0.5 A each );
- STATUS lamp absorbed current ( max 0.2 A );
- MUTING lamp absorbed current ( max. 0.5 A ).

<b>0 V</b>	0 Vdc Power supply
------------	--------------------

Connect to 0 V of 24 Vdc power supply.

<b>PE</b>	Protective Earth
-----------	------------------

Connect to the ground of machine.

## Outputs

<b>OSSD-0</b>	Safety output 0
<b>OSSD-1</b>	Safety output 1

Safety PNP outputs, OSSD-0 and OSSD-1.

Use the OSSD-0 and OSSD-1 outputs to stop the dangerous movement of the machine through contactors with guided contacts controlled by the barrier, or by safety relay module or safety PLC.

The OSSDs outputs go in ON state ( +24 V ) if are satisfy the following conditions:

- barrier aligned and activated by reset command,
- protected area free,
- correct connections and no internal fault.

The barriers with MUTING can activate the OSSDs also using the guard override function.

The OSSD outputs go or remain in OFF state ( 0 V ) if it is not satisfied one or more of the above conditions.

The outputs are dynamically monitored. To check the absence of fault, when the OSSDs are in ON state, will be switched in OFF state for 0,2 msec with a period = response time – 1 msec

## ELECTRICAL CHARACTERISTICS OF THE OUTPUTS

DESCRIPTION	
Nominal output current for resistive load	500 mA
Max. output current for resistive load	500 mA
Nominal output current for inductive load	500 mA
Max. output current for inductive load	500 mA
Max. capacitive load with no resistive load applied	1 $\mu$ F
Max. capacitive load with resistive load of 48 OHM applied	2 $\mu$ F
Max. output voltage in OFF-State	0.1 V
Max. output current in OFF-State	10 $\mu$ A ( leakage current )
Max. resistance between the OSSDs outputs and the load	22 $\Omega$

<b>EDM</b>	Input for External Device Monitor
------------	-----------------------------------

Monitoring of external contactors.

Allow to check the external contactors using their series of the NC contacts.

The contactors shall have forced guided contacts.

With OSSD in OFF state on the EDM input shall be present 24 V.

With OSSD in ON state on the EDM input shall be present 0 V.

The barrier checks the EDM input after the power on, and at every change state of the OSSDs.

The barrier checks the time of ON / OFF commutation, it shall be max 500 ms.

**If the EDM is not used, connect it to the OSSD-0 output.**

## Reset

<b>START-E</b>	Input for reset selection
<b>START</b>	Input for restart pushbutton

## AUTOMATIC RESET

With the selection of the automatic reset, the OSSDs outputs follow the state of the barrier.

When the protected area is free, automatically the OSSDs go in ON state.

Take into consideration that in this case there is no the start interlock. If this function is necessary, verify that other means are present to stop the machine at the power on.

## MANUAL RESET

One push button NO shall be activated to start or re-start the OSSD-0 and OSSD-1 after the interruption of the beams or when the ESPE is turned on at first time.

This pushbutton must be located outside the dangerous area, and shall not be possible to activate it from inside of the dangerous area. It shall be located where is possible to check the dangerous area. The manual reset has the function of start interlock.

This system shall be utilized when the barrier is employed for the protection of a dangerous passage.

The following table show the reset setup.

<b>START- E</b>	<b>START</b>	<b>Function selected</b>
0 V	24 V	AUTOMATIC RESET
24 V	NO / 24 V	MANUAL RESET

## Muting

The muting function generates a temporary suspension of the protective function of the barrier in order to ensure the normal passage of the material through the protected area.

If the MUTING function is active, the interruption of the beams doesn't disable the OSSDs outputs.

### MUTING with two sensors.

The muting function is activated through the activation of two sensors within 2 sec of each other.

Any others conditions applied to the sensors don't activate the MUTING function.

During the MUTING the two sensors shall be always active. Disabling a muting sensor terminates the muting function.

A signalling MUTING lamp can be connected to MUTE-S output to indicate that the MUTING function is active.

If for any reason, the muting doesn't activate, the interruption of the beams will determine the block of the machine. In this case the cycle can be restarted using the **GUARD-OVERRIDE** command.

## MUTING Enable

<b>MUTE-E</b>	MUTING Enable input
---------------	---------------------

Enable input for MUTING function.

If connected to 24 Vdc the MUTING function is enabled and the E-MUTE indicator is ON, otherwise if floating or connected to 0 V, the MUTING function is not enabled, and the E-MUTE indicator is OFF.

## EXTERNAL MUTING

<b>MUTE - 0</b>	EXTERNAL MUTING - sensor 0 input
<b>MUTE - 1</b>	EXTERNAL MUTING - sensor 1 input

The muting function is activated through the contemporary activation ( within 2 sec ) of the MUTE –0 and MUTE –1 input.

For the muting input:

If connected at 24 Vdc

MUTE input activated, the L.E.D. SENS 0 and 1 are ON

If connected to 0 V or floating

MUTE input deactivated, the L.E.D. SENS 0 and 1 are OFF.

## ARMS FOR AUTOMATIC MUTING

The mobile arms of the model LXM, LPM, TXM, TPM, are connected to the vertical barrier through M12 5 poles female cable.

External sensors for the LXi, LPi, TXi, TPi models are connected via M12 5-pin female cables.

Inputs for automatic muting sensors.

<b>MUTE – B1</b>	Arm muting sensor 1 input
<b>MUTE – B2</b>	Arm muting sensor 2 input
<b>MUTE – B3</b>	Arm muting sensor 3 input
<b>MUTE – B4</b>	Arm muting sensor 4 input

## GUARD OVERRIDE

<b>GOVR- 0</b>	Guard Override 0 input
<b>GOVR- 1</b>	Guard Override 1 input

Inputs for external guard override commands.

If they are connected to 24 Vdc, the GOVR-0 / 1 are active, and OVER indicator is ON,

If they are floating or are connected to 0 V, the GOVR-0 / 1 aren't active and OVER indicator is OFF.

The command for the GUARD OVERRIDE is formed by a couple of contacts NO (i.e. key selector with spring return) that shall be activated simultaneously within 300 msec. If this don't happens the guard-override function will not be activated.

The opening of only one contact cause the stop function.

The time out is 3 minutes. After this time, the guard-override function is terminate.

The OVER indicator is ON if the guard-override function is active.

The OVER indicator blinks if are past the 3 minutes of TIME OUT, or if the MUTING conditions have been restored ( vertical beams are free and MUTING sensors are free) and the GUARD OVERRIDE command is still active.

When disable the GUARD-OVERRIDE function, if the beams of the vertical barrier and of the muting sensors are free, the OSSD will remain in ON state, regardless of the reset mode.

The GUARD-OVERRIDE function can be utilized only at the following conditions:

- the muting enable command is active, and
- mistake of sequence of muting sensors, and
- at least one beam of vertical barrier is interrupted, and
- the correct activation of the GUARD OVERRIDE commands.

The GUARD-OVERRIDE is not performed if :

- the muting enable command is not active, or
- one command of GUARD OVERRIDE is OFF, or
- time out expired, or
- all mute inputs and the beams are free.

If the GUARD OVERRIDE has been successfully activated, the **OVER** indicator is ON.

<b>MUTE-S</b>	Output MUTING Lamp
---------------	--------------------

Output for MUTING lamp.

The muting lamp is active ( +24 V ) when the MUTING function is active and vice-versa.

<b>MUTE-F</b>	Muting phase, main beams interrupted
---------------	--------------------------------------

This output is active ( +24 V ) only when the muting function is active and the beams of the “ Sensitive Height “ are interrupted.

It can be used to indicate the effective passage of the pallet.

<b>TIME- 0</b>	Input 0 - configuration MUTING time
<b>TIME- 1</b>	Input 1 - configuration MUTING time

Input for the selection of the duration of MUTING.

These inputs are only on the model of light curtain type **E1, E2, E3**.

The configuration is set using one or two wires on the connector of the receiver and is stored at power on of the light curtain.

Any configuration changes during normal operation will not be accepted until a subsequent cycle OFF / ON of the light curtain.

Selecting inputs, as shown in the table below, we can set the duration of the MUTING function.

In the E1, E2 versions, TIME-1 is internally connected to 0 V.

SETTINGS OF MAX MUTING TIME			
TIME - 0	TIME - 1	Maximum duration of the Muting	Indications
0V	0V	1 minute	SENSE1=OFF - SENSE2=OFF
0V	+24V	24 hours	SENSE1=OFF - SENSE2=ON
+24V	0V	90 minutes	SENSE1=ON - SENSE2=OFF
+24V	+24V	1 minute	SENSE1=ON - SENSE2=ON

If an error occurs on the connection of the TIME-0 and TIME-1 signals caused for example by broken cables, fault inside the light curtain, the maximum MUTING time will be set to the lowest value (1 minute).

## KEEPER RECEIVER - EXTERNAL ARMS CONNECTION

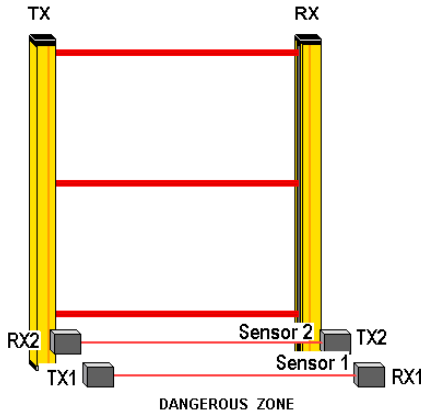

The barriers of the series TPi3, TXi3, LPi3, LXi3 must be connected to external muting sensors provided by the customer, these versions allow maximum installation flexibility for non-standard applications.

The transmitter is provided with only M12 connector to power supply and input command TEST.

The receiver is provided with the standard connections + 1 or 2 cables

with M12 5-pin female connectors to which the client will connect the muting sensors.

The sensors can be photoelectric sensors, proximity, capacitive, micro mechanics switches, with N.O. contacts or PNP outputs.

To activate the muting function the sensors must provide 24 Vdc when are activated. Sensors and barrier must have the common 0 V.

The following tables shows the connections for external MUTING sensors. Refer to page 16 for details of identification of the sensor and its location in the geometric configuration choice.

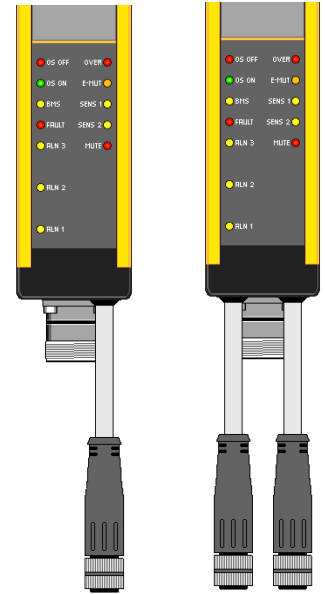

**TXi3  
LPi3  
LXi3**

**TPi3**

### VERSION T AND L WITH CROSSED BEAMS, L WITH PARALLEL BEAMS

Receiver KP- ... -						
Pin N	Wire colour	Function	Description	Type	Level	
M12 4 poles						
1	Brown	+24V	Positive power supply	OUT	+24 Vdc +/- 10%	0,5 A
2	White	MUTE B1	MUTING 1 input sensor	IN	0 - 24 Vdc	10 mA
3	Blue	GND	0V power supply	IN	0V	
4	Black	MUTE B2	MUTING 2 input sensor	IN	0 - 24 Vdc	10 mA
5	Grey	PE	Ground	-	-	

### VERSION - T WITH PARALLEL BEAMS

Receiver KP- ... -						
Pin N	Wire colour	Function	Description	Type	Level	
M12 5 poles right						
1	Brown	+24V	Positive power supply	OUT	+24 Vdc +/- 10%	0,5 A
2	White	MUTE B1	MUTING input sensor 1	IN	0 - 24 Vdc	10 mA
3	Blue	GND	0V power supply	IN	0V	
4	Black	MUTE B2	MUTING input sensor 2	IN	0 - 24 Vdc	10 mA
5	Grey	PE	Ground	-	-	
M12 5 poles left						
1	Brown	+24V	Positive power supply	OUT	+24Vdc +/- 10%	0.5 A
2	White	MUTE B3	MUTING input sensor 3	IN	0 - 24 Vdc	10 mA
3	Blue	GND	0V power supply	IN	0V	
4	Black	MUTE B4	MUTING 5input sensor 4	IN	0 - 24 Vdc	10 mA
5	Grey	PE	Ground	-	-	

## INDICATIONS and DIAGNOSTIC

Below are the main functions related to each indicator and its status.

### EMITTER

<b>POWER-TEST</b>	YELLOW - Power On & Test
-------------------	--------------------------

If the indicator is ON, the power supply is connected correctly.  
If the indicator blinks, the TEST function is active.

<b>FAULT</b>	RED - Fault
--------------	-------------

If the indicator is ON, the light curtain is stopped due to an internal failure.  
In this case contact the technical support.

If the FAULT and POWER-TEST indicators are both lit, there is a problem with the connection cable between the MUTING arm and the vertical.

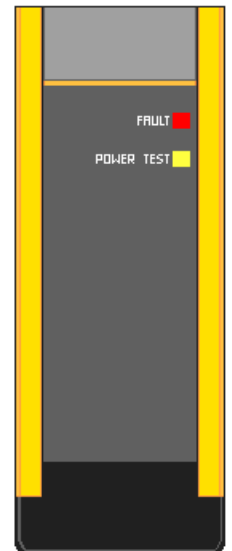

### RECEIVER

<b>OS OFF</b>	RED – Status of OSSD0 e OSSD1
---------------	-------------------------------

The OSSD0 and OSSD1 outputs are in OFF state.

<b>OS ON</b>	GREEN - State of static OSSD0 e OSSD1
--------------	---------------------------------------

The OSSD0 and OSSD1 outputs are in ON state.

<b>BMS</b>	YELLOW - Waiting external reset
------------	---------------------------------

If all beams of the sensitive zone are aligned and the manual RESTART is selected, the indicator is ON. After pressed and released the restart button, the indicator is OFF.

<b>FAULT</b>	RED - Fault
--------------	-------------

If the indicator is ON, the light curtain is stopped due to a failure.

The fault may be due to incorrect wiring or internal fault.  
Check the wiring, if no error is detected, contact technical support.

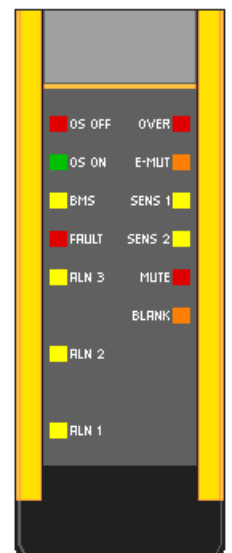

<b>ALN1</b>	YELLOW - BARGRAPH Led 1
<b>ALN2</b>	YELLOW - BARGRAPH Led 2
<b>ALN3</b>	YELLOW - BARGRAPH Led 3

The three LEDs provide indications on the beams alignment. This simplifies the alignment of the light curtain, particularly in case of difficult installations, for example with the use with mirrors or on long range. At any indicator is associated a percentage of beams aligned.

The indications given are summarized in the following table.

<b>ALN1</b>	<b>ALN2</b>	<b>ALN3</b>	<b>DESCRIPTION</b>
OFF	OFF	OFF	No beams aligned, or the first beam is interrupted
BLINK	OFF	OFF	The number of aligned beams is less than 1/3 of total beams
ON	BLINK	OFF	The number of aligned beams is between 1/3 and 2/3
ON	ON	BLINK	The number of aligned beams is between 2/3 up to maximum
ON	ON	ON	All beams are aligned

The blink period is 1 second.

When the OSSDs go from OFF to ON state, the alignment indicators will turn OFF.

<b>OVER</b>	RED - GUARD OVERRIDE function
-------------	-------------------------------

If the GUARD OVERRIDE function is active the indicator is ON.

If there is an error on the function activation the indicator blinks, see pag 33.

<b>E-MUTE</b>	ORANGE - MUTING Function enabled
---------------	----------------------------------

If the MUTING function is enabled the indicator is ON.

<b>SENSE-1</b>	YELLOW - External Muting Sensor 1
----------------	-----------------------------------

If the MUTING sensor 1 is active the indicator is ON.

In versions E1, E2, E3 indicates the status of the selector 1 of muting time duration.

<b>SENSE-2</b>	YELLOW – External Muting Sensor 2
----------------	-----------------------------------

If the MUTING sensor 2 is active the indicator is ON, and vice-versa.

In versions E3 indicates the status of the selector 2 of muting time duration.

<b>MUTE</b>	Red – gives the function of MUTING
-------------	------------------------------------

If the MUTING function is active the indicator is ON.

<b>BLANK</b>	Not used
--------------	----------



Additional indication for troubleshooting.

**MANUAL and AUTOMATIC RESTART**

If an error occurs in the reset setting, the **FAULT** indicator is ON and **ALN1** indicator blinks. The light curtain is locked.

Turn OFF the light curtain, check the reset settings and then turn ON the barrier.

The main causes can be :

- restart wires not connected properly;
- push button of manual reset is NC instead of NO;
- push button of manual reset pressed during the turn on of the barrier.

**OSSD 0 / OSSD 1**

If an error occurs on the OSSD output, **OS OFF** and **FAULT** indicators are ON and **ALN2** indicator blinks.

The light curtain is locked.

Turn OFF the barrier, check the OSSD output connections and then turn ON the power supply.

The main causes could be :

- short circuit between OSSDs;
- OSSD connected to +24V or 0V;
- capacitive load beyond the limit, excessive cable length ;
- wrong connection of the outputs;
- internal fault.

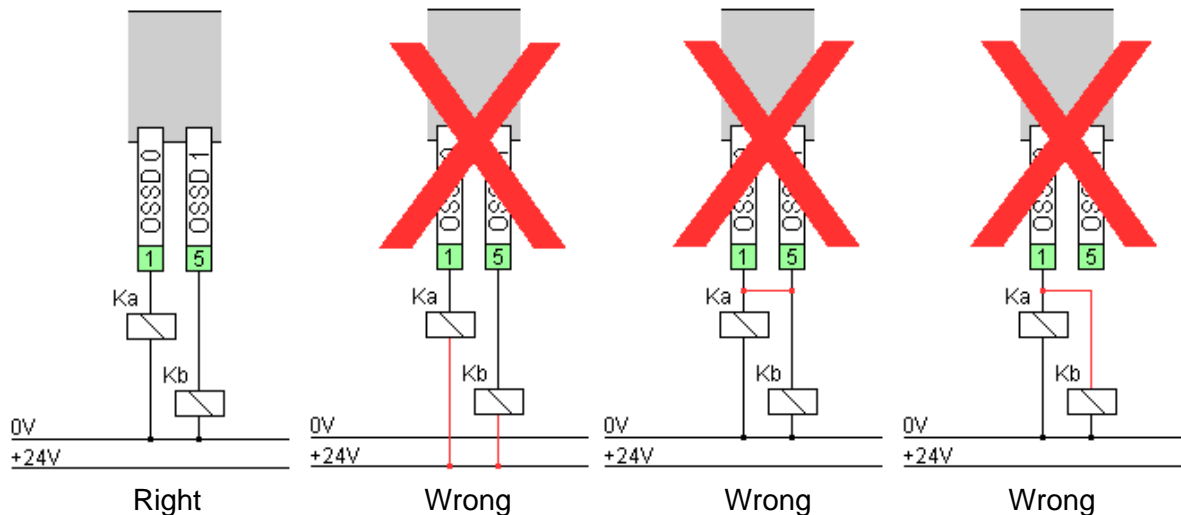

**EDM**

If an error occurs on the EDM function, **OS OFF** and **FAULT** indicators are ON and **ALN3** indicator blinks.

The light curtain is locked.

Turn OFF the barrier, check the EDM connections and then turn ON the power supply.

The main causes can be :

- wire not connected or connected to 0 V;
- contact of external device open when the barrier is in OFF state;
- voltage to external device not present or not correct ;
- external contactor defective.

In Manual reset if the safety conditions are met the BMS indicator is ON.

Press and release the RESTART push button to activate the barrier.

In Automatic reset if the safety conditions are met the barrier will be activated.

In the case that the external contactors are not connected directly to the barrier, and do not switch when the OSSDs pass in the ON state, the barrier goes cyclically into the OFF state for 15 seconds, and after, if the conditions allow it, resumes the ON state testing again the EDM input.

**If the EDM is not used, connect it to the OSSD-0 output.**

**GUARD OVERRIDE**

At the power on, if an error occurs in the GUARD OVERRIDE function, the **OS OFF** and the **FAULT** indicator are ON, and the **OVER** indicator blinks. The light curtain remain locked.

During the normal operation if an error occurs on the GUARD OVERRIDE function, the **OS OFF** indicator is ON, and the **OVER** indicator blinks

Turn OFF the barrier, check the GUARD OVERRIDE connections and then turn ON the power supply.

The main causes could be :

- one or two contacts are normally closed instead of normally open ;
- break of one contact ;
- end of the GUARD OVERRIDE time out ;
- non simultaneous closing of contacts in the maximum expected time of 300 ms.

## SERVICE AND TEST

### Attention

Each repair operation should be performed only by GREIN authorized technicians.

### Putting into service and tests at regular intervals

The installer that put the equipment into service shall have all necessary information about the machine or the plant, and the installed ESPE KEEPER.

The testing shall cover the correct interaction of the ESPE and the control system of the power-operated working equipment, the safe state and the construction in compliance with the equipment-specific safety rules. The test-relevant information provided by the machine or plant manufacturer (e.g. a press manufacturer) shall always be observed when testing.

A distinction is made between the following types of test:

### Testing prior to put a device into service for the first time and after modifications (approval tests)

An authorized, qualified person should test the ESPE prior to its being put into service for the first time, and after its - or its components / units involved in the safety function - having been modified.

All changes of the circuit/switching, the control system, the ESPE configuration and the involved components/units affecting the safety function are considered a modification.

Those tests are to determine that the power-operated working equipment (e.g. the press) fulfils the requirements when the ESPE is employed, and that the correct operation of the components/units involved in the safety function is ensured for the interaction with the ESPE. Furthermore, type of use and installation of the ESPE shall be tested.

### Periodical tests

Periodical tests serve the purpose of systematically detecting and removing safety-relevant deficiencies (e.g. in the event of modification or manipulation) of the protective equipment of the machine or facility which occur after the machine/facility having been put into service. Type, scope and time intervals to be followed are listed in clause "**SETTING UP AND TEST**" of the ESPE's instructions for use, and shall be determined and specified for each individual working equipment. All tests, it shall comply with national regulations working type C. The test results shall be recorded and writing in a report which is to be signed by the inspector. The report shall be kept at the installation site of the machine or facility, respectively.

### Maintenance

Periodically clean the front of the barriers using a soft damp cloth.

Do not use solvents or abrasives. For particularly hostile environments where is required a very intense cleaning you can request the glass protection that allows the use of more aggressive solvents.

## SETTING UP AND TEST

### FINAL CHECK BEFORE STARTING

Before connecting the curtain to the power supply, ensure that:

- the value of power supply is 24 Vdc;
- connection cables of emitter and receiver to machine are correct.

When the barrier is aligned, if AUTOMATIC RESTART is set, the OS ON indicator will turn ON and the 24 Vdc is present on OSSDs outputs.

Otherwise, if the MANUAL RESTART is set, the BMS indicator is ON and OS ON is OFF, then press and release the START button to activate the barrier ( 24 Vdc is present on OSSDs outputs, BMS is OFF and OS ON is ON ).

Perform the periodical test follow the verifications listed below:

**Hint:** To ensure major safety, perform these tests in manual reset.

### Daily testing of the protective device by authorized personnel.

By the operator, daily or prior to each work session by means of complete coverage of every beam of light curtain using the test rod. A test rod is supplied with the barrier up to 40 mm resolution.

Move the test rod slowly through the length of the protective field at three different points:

- 1) Protective field limits / protective field markings close to sender (access opening);
- 2) Protective field limits / protective field markings close to receiver;
- 3) Protective field limits in middle between transmitter and receiver.

During the test, the BMS indicator must be turned OFF. If during this test the BMS indicator is lights up, it is necessary to verify the mechanical installation in accordance with the minimum distance to avoid the reflecting signal as reported in page 8.

Check for damage to the protective device, in particular the mounting, electrical connection.

Check for wear or damage to the housing, front screen or electrical connection cable.

Check that people or body parts can only access the danger zone through the protective field.

If one or more errors occur during the test, the machine must be shut down.

If no errors are detected, the barrier is ready for use, select automatic or manual reset as required.

## EXTERNAL MUTING DETAILS

Before to use the muting function should be evaluated :

- a. the application;
- b. the installation of the two sensors;
- c. the risk of the machinery or the plant.

In order to use the muting function, thus the knowledge and observance of the machinery / equipment-specific standards and the relevant standards or guidelines for machine safety / protective devices.

The following overview, which does not claim to be exhaustive, gives some of the major standards:

EN 61496-1	Safety of machinery - Electro-sensitive protective equipment
EN 60947-5-3	Low-voltage switchgear and controlgear
EN ISO 13855	Safety of machinery - Positioning of protective equipment
IEC/TS 62046:2008	Safety of machinery - Application of protective equipment to detect the presence of persons

### **!! Warning !! SAFETY INSTRUCTION !! Warning !!**

Failure to observe the following instructions may lead to most severe injuries and death.

- Observe the above-mentioned standards as regards configuration, installation and operation of muting systems.
- Take measures to exclude common mode failures.
- Take measures to exclude failures by cross circuits.
- Take measures to prevent the muting function from being tripped by persons.
- Please note that a muting function shall not be initiated until the preceding muting function has been terminated.
- Take measures to safeguard maintenance gates to the danger zones in compliance with the necessary safety level.

The muting function integrated in the KEEPER is appropriate for applications where the muting sensors used to initiate the muting function are the same as those used to terminate the muting function.

#### **Muting sensors location and positioning:**

The muting sensors shall be located such that the user is not able to manipulate / defeat the muting sensors in order to activate the muting function. The above-mentioned standards and safety instructions shall be observed.

This means e.g. for safeguarding the access with use infrared emitter-receiver type as sensors:

- the beams of the muting sensors shall always meet in the danger zone.
- the muting sensors shall be positioned / located such that the light grid is interrupted before it is possible to reach the beam intersection point.

### Type and connection of the sensors

The sensors can be of every type (also no safety sensor) because the internal circuit of the barrier provide the control of the same and to block on the case of damage .

These components can be choice between proximity, mechanical micro , light curtains, etc. as specify on the standard machinery. When active the muting sensor must supply 24 Vdc.

To avoid common mode failures the conductors must be of type armed against the mechanical crushing and screened electrically. Their installation must happen on two separate runs for avoid that a common cause could damage both the connections with a short circuit.

### Sequence function of muting, MUTE-0 and MUTE-1 input sensors

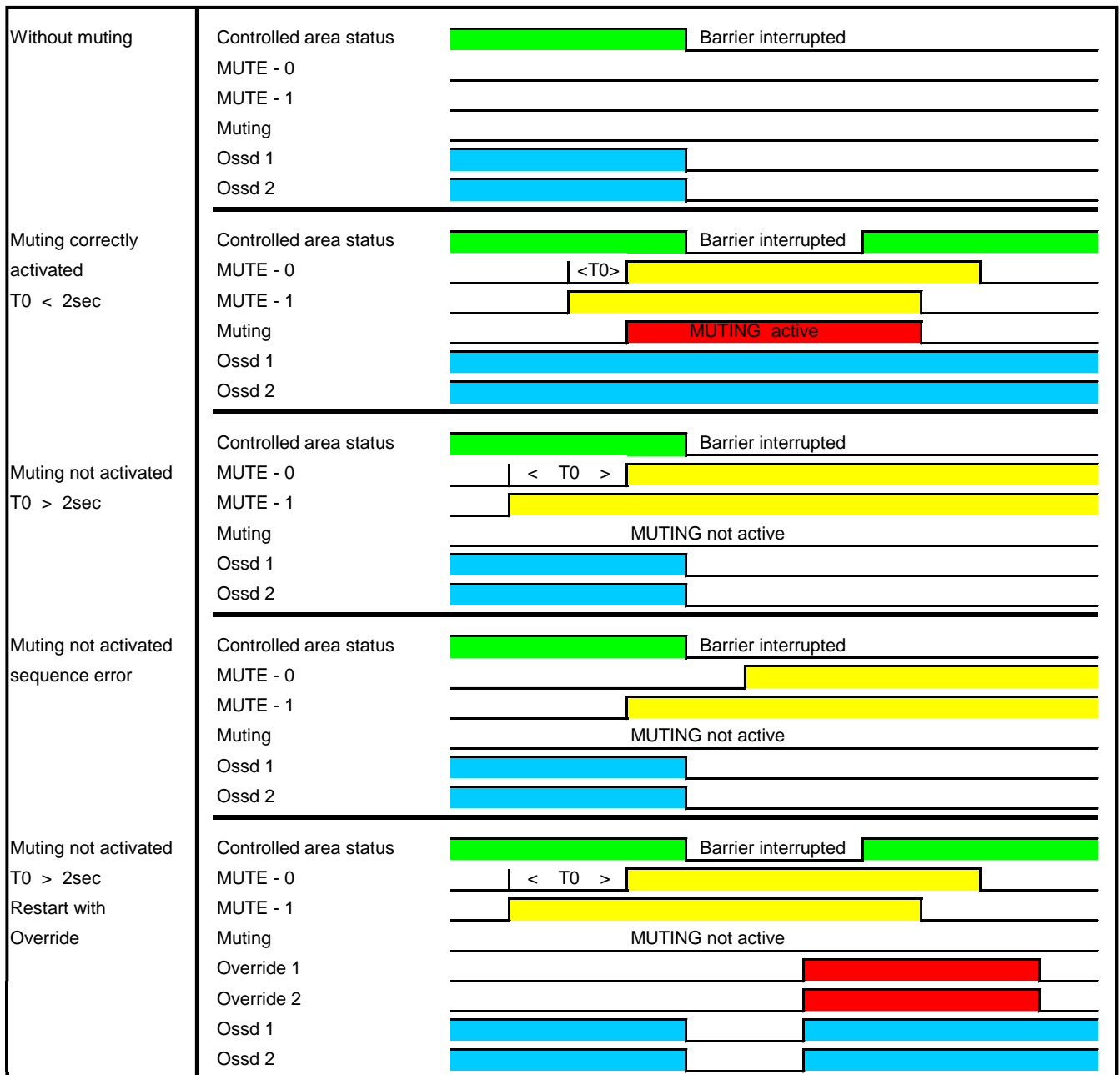

## DETAILS INTERNAL AUTOMATIC MUTING FUNCTION

The models T and L can support the internal and external sensors for the realization of the MUTING beams and the resulting bounding the hazardous area.

The external sensors that can be applied are proximity switch, capacitive, mechanical, etc.

The output signal from these sensors must assume a voltage level of + 24 V when the sensor is active. In the case of optical sensors, the receiver output signal assume + 24 V when the infrared beam is interrupted.

In the following figures there are some types of applications of internal and external sensors with use of optical type sensors.

For model E, the maximum duration of the MUTING function is fixed at 24 hours. For E1, E2, E3 model, the duration of the muting time is selectable with TIME-0 and TIME-1 signals, as described on page 29.

### L MODEL WITH CROSSED BEAMS

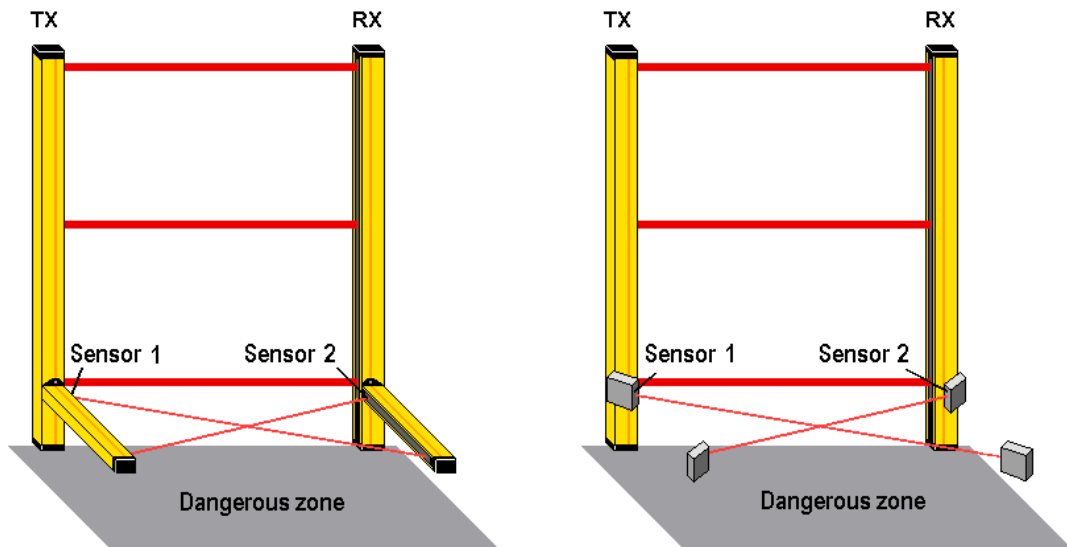

This model is unidirectional and is used only for one-way openings with pallet exit. The sensors form a cross between the rays of MUTING. The MUTING arms must be positioned within the dangerous zone. The interruption within 2 seconds of the 1 and 2 sensor, will activate the MUTING function. The barrier will exclude the safety protection( vertical beams )within 100ms after the activation of the last sensor. When one of the two sensors is deactivated ( not interrupted ) the MUTING function ends.

The light curtain restores the safety protection within 5 sec from the release of the first sensor. In this time the pallet must leave the vertical barrier. In any case the muting function ends after 2 seconds from when the vertical barrier is released.

In case of exceeding times or sequence mistake, the OSSD outputs will pass from the ON state to the OFF. The OVERRIDE function can be used to restore the system.

In this application, the minimum distance between two consecutive pallets must be roughly less than 100 mm, or as a minimum:

distance between pallet [mm] =  $V + 260$                       where V = speed of transport in mm / s.

L MODEL WITH CROSSED BEAMS - ACTIVATION SEQUENCE

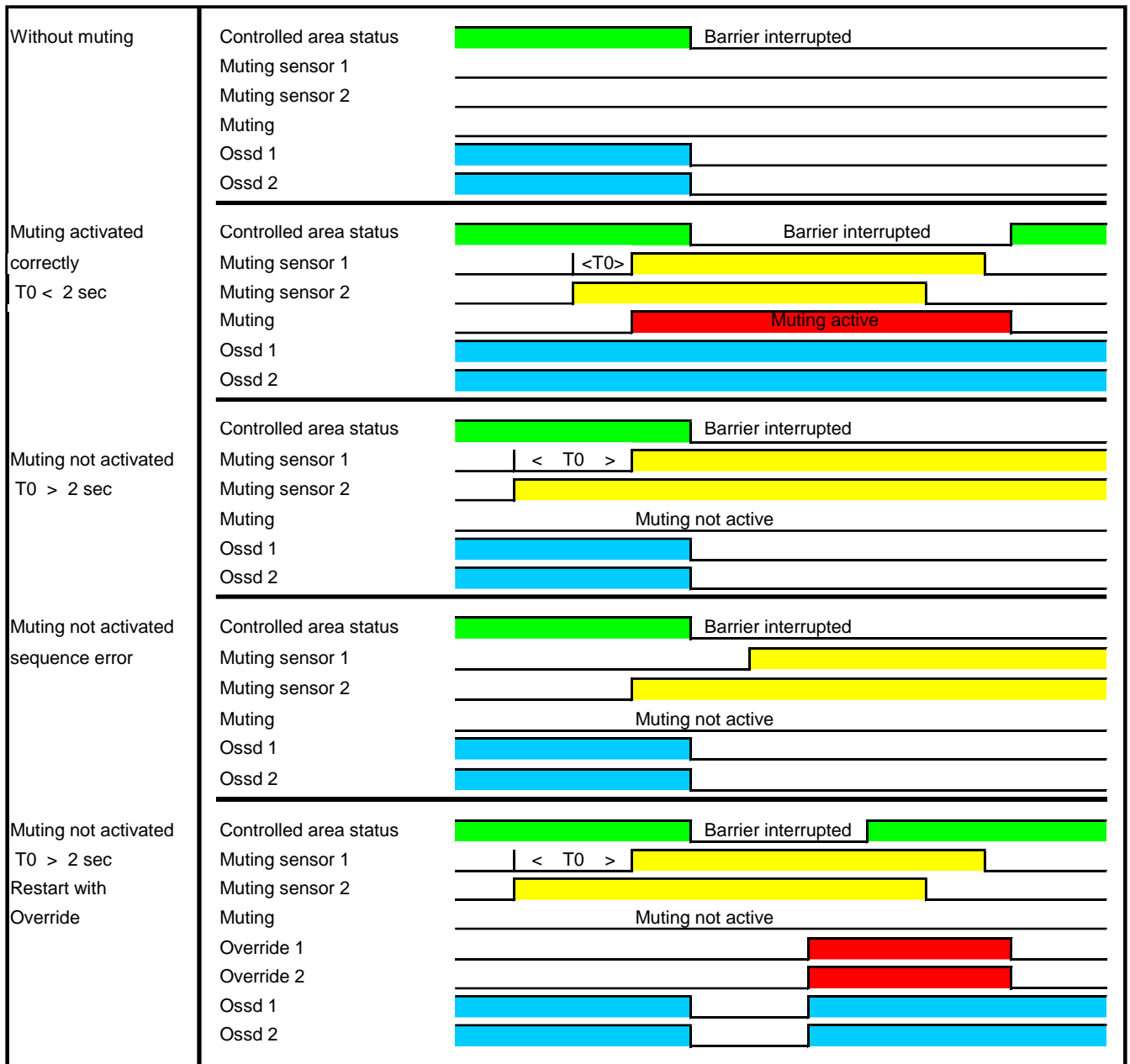



**T MODEL WITH CROSSED BEAMS**

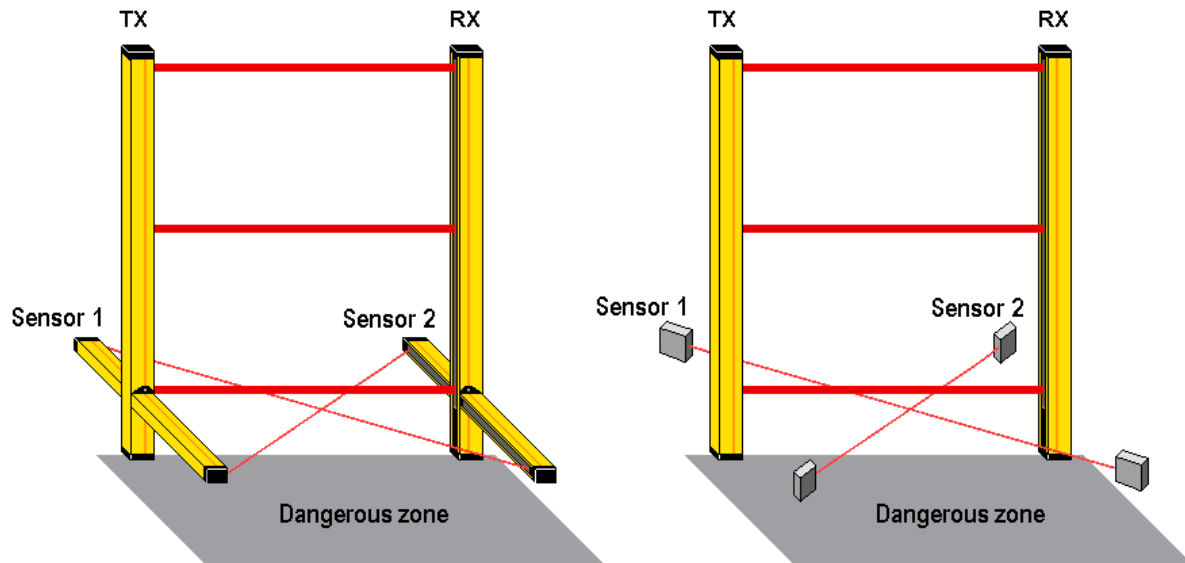

This model is bidirectional and is used for input / output protection.

The sensors form a cross between the MUTING beams.

The MUTING arms must be positioned within the cross point in the dangerous zone.

The interruption within 2 seconds of the 1 and 2 sensor, will activate the MUTING function.

The barrier will exclude the safety protection ( vertical beams ) within 100 ms after the activation of the last sensor.

When one of the two sensors is deactivated ( not interrupted ) the MUTING function finishes.

The light curtain restore the safety protection within 100 ms from the deactivated of the first sensor.

In this time the pallet must leave the danger zone. If the working material is still inside in the danger zone, the OSSD outputs change state from ON to OFF, in this case, the OVERRIDE function can be used to restore the system.

In this application, the minimum distance between two consecutive pallets shall be approximately less than 100 mm, or more than 350 mm.

T MODEL WITH CROSSED BEAMS - ACTIVATION SEQUENCE

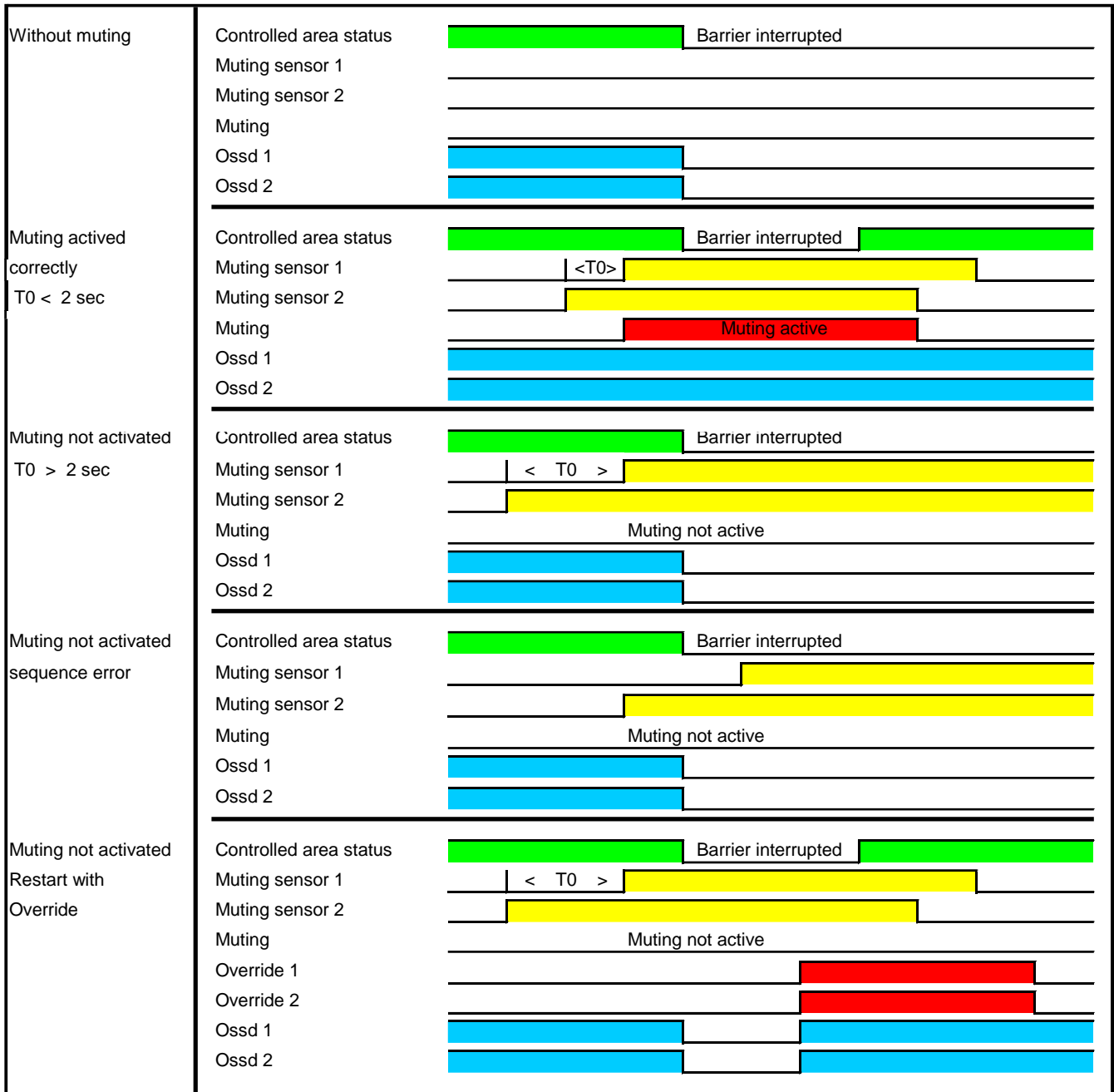

**L MODEL WITH PARALLEL MUTING BEAMS**

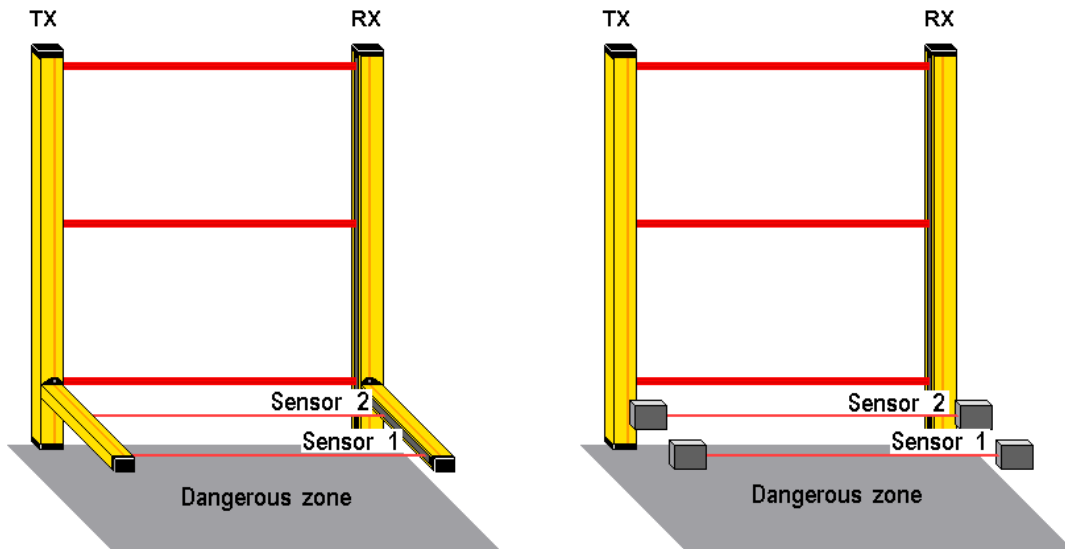

This barrier model is unidirectional and is used for the protection of output gates in palletizer machines. The sensors forms two parallel beams.

The MUTING arms must be positioned within the dangerous zone.

The MUTING function is active when occurs the interruption of sensor 1 and then the sensor 2.

The interruption time of the muting beams must be between 0.3 to 5 seconds.

The disabling of the MUTING function occurs with the deactivation of the sensor 1 and then of the sensor 2.

The light curtain restores the safety protection within 5 sec from the release of the sensor 2. In this time the pallet must leave the vertical barrier. In any case the muting function ends after 2 seconds from when the vertical barrier is released.

In case of exceeding times or sequence mistake, the OSSD outputs will pass from the ON state to the OFF. The OVERRIDE function can be used to restore the system.

In this application, the minimum distance between two consecutive pallets shall be:

$$\text{minimum distance between pallet [mm]} = V + 260 \quad \text{where } V = \text{speed of transport in mm / s}$$

In case of use of external sensors, to avoid optical interference between the adjacent photocells is advisable to use models with narrow emission angle, and alternate transmitters and receivers as shown in this figure.

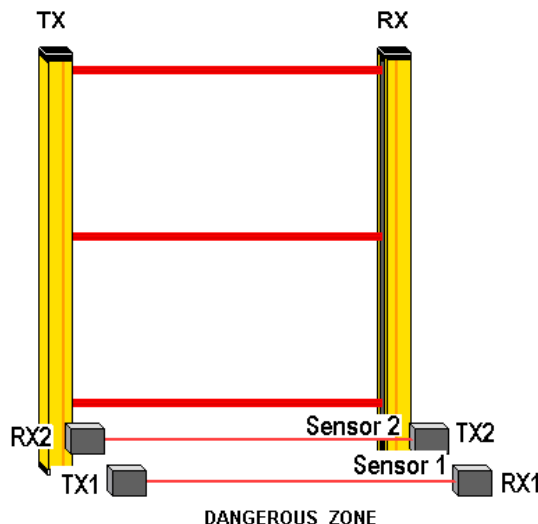

L MODEL WITH PARALLEL MUTING BEAMS - ACTIVATION SEQUENCE

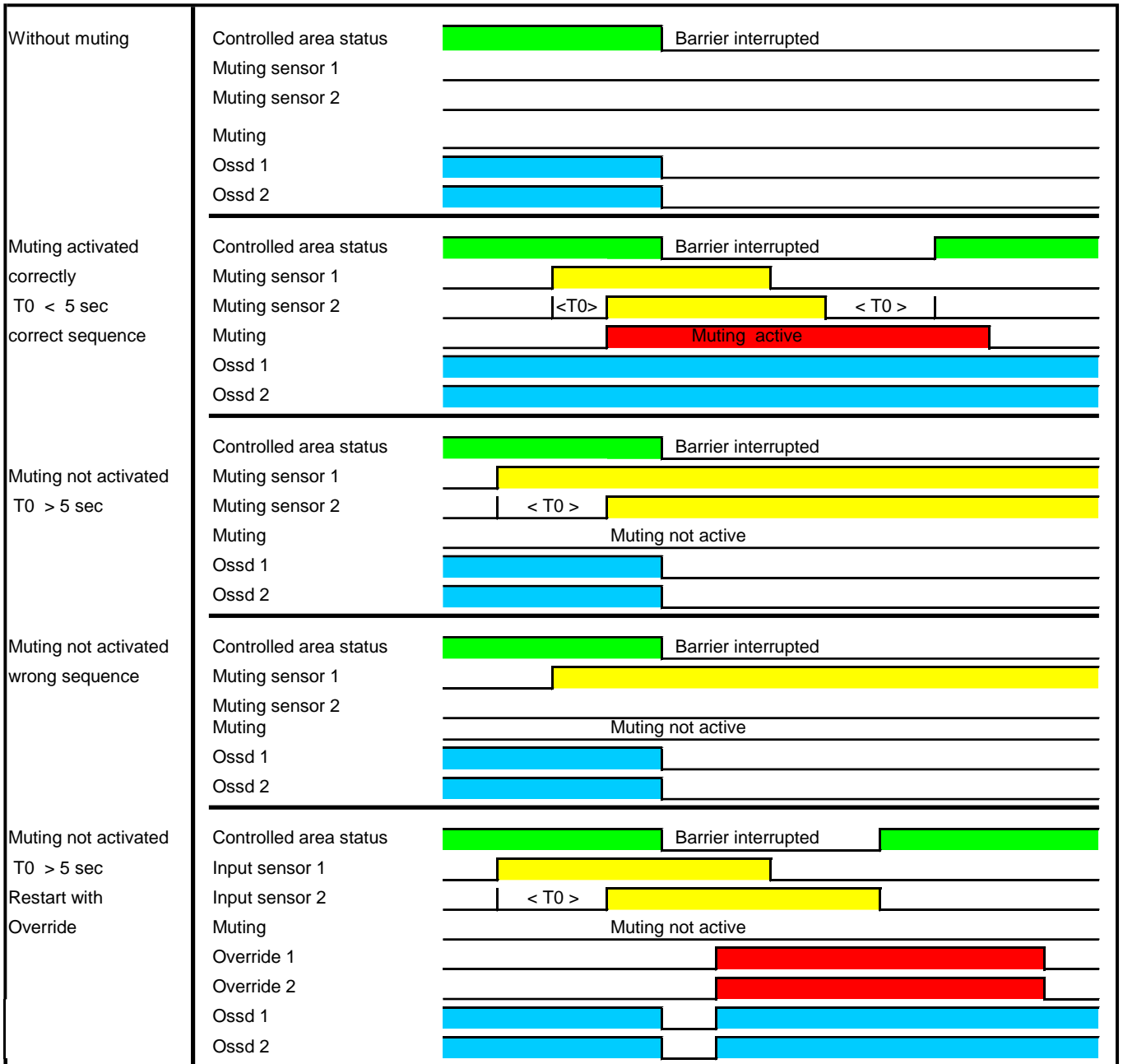

T MODEL WITH PARALLEL MUTING BEAMS

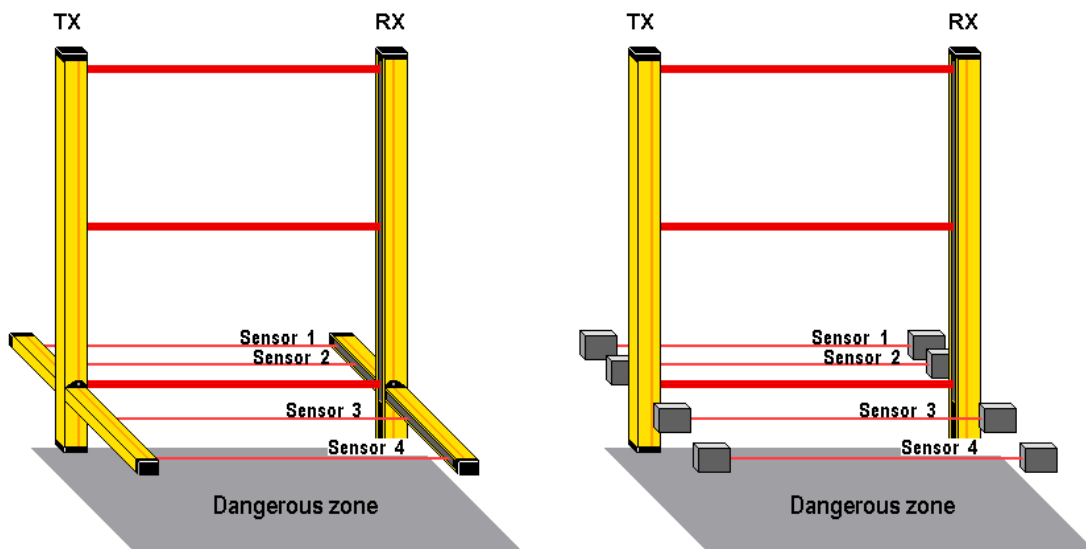

This barrier is bidirectional and is used for the protection of input and output in palletizer machines. Inside to each arm there are two sensors forming a total of four parallel beams. The activation of the MUTING function is sequential. The interruption of the sensors 1, 2, 3, 4 and vice versa 4, 3, 2 and 1 active the muting function. The interruption of the sensors 1 and 2 (or 4 and 3) must be between 0.3 and 5 seconds. The deactivation of the sensors 1, 2, 3, 4 and vice versa 4, 3, 2, 1 disables the muting function.

For this version, the minimum distance between two consecutive pallets shall be greater than 510 mm.

In case of using external sensors, to avoid optical interference between adjacent photocells is advisable to use models with narrow beam angle, and alternate transmitters and receivers.

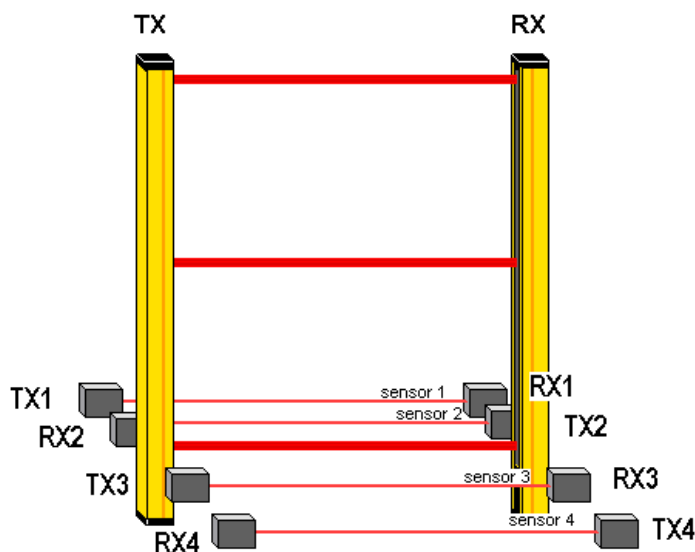

T MODEL WITH PARALLEL MUTING BEAMS - ACTIVATION SEQUENCE

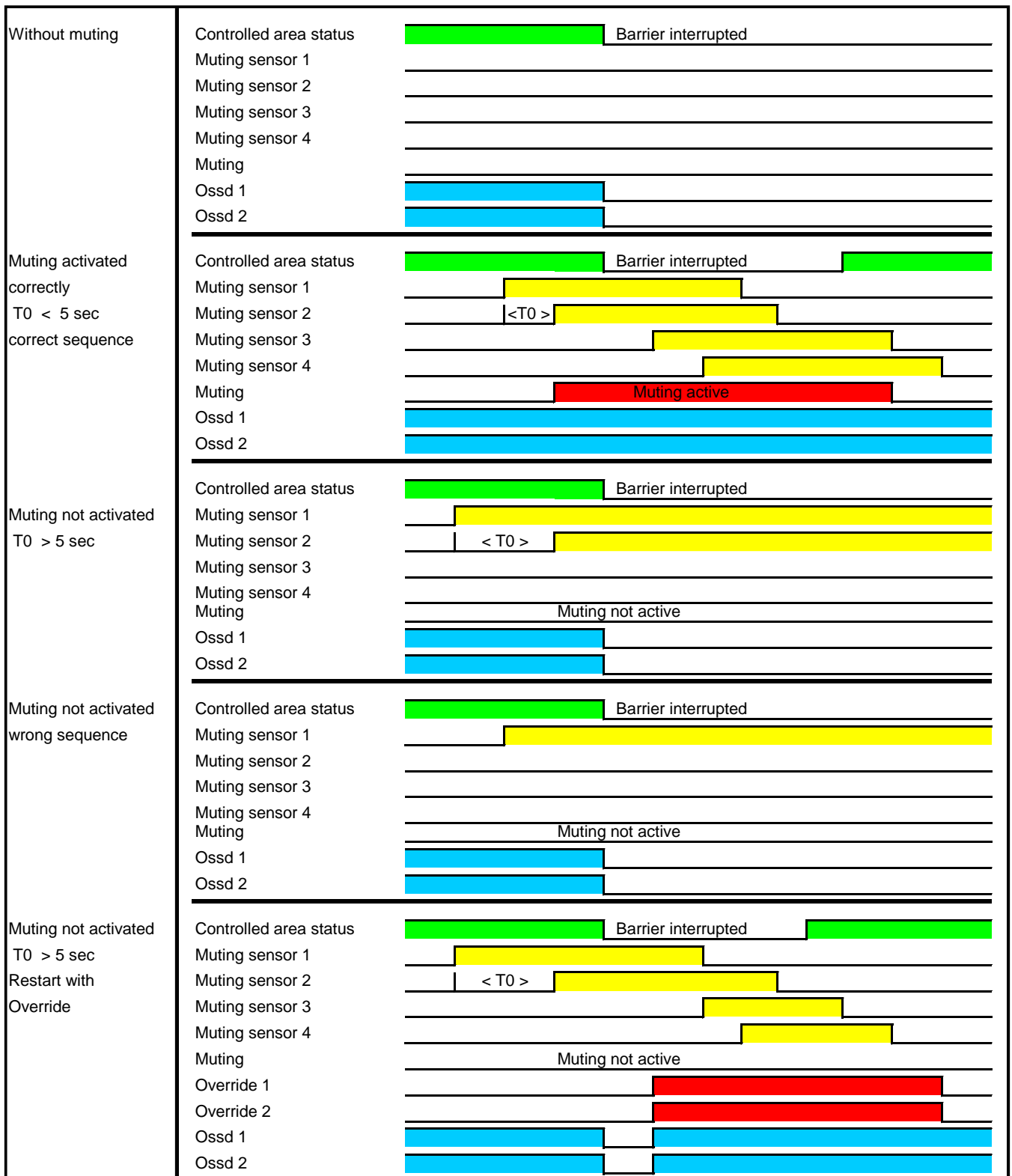

## MUTING COMBINATION

The KEEPER light curtain can activate and maintain the MUTING function with external muting (MUTE-0 and MUTE-1 input sensors), internal muting (L or T configurations) or by a combination of both.

The activation conditions and timings are identical to those analyzed for the individual types of MUTING (internal and external).

## PLACEMENT AND ADJUSTMENT OF MUTING ARMS

In order to avoid problems of discontinuous darkening of the "MUTING" sensors on the part of the material in transit, the arms are equipped with horizontal and vertical adjustment. Appropriate adjustments in height and angle allow to vary the detection position.

To make the adjustment:

- loosen the screws holding the arm;
- operate on the arms to make the necessary adjustments of height and rotation;
- retighten screws to lock the arms.

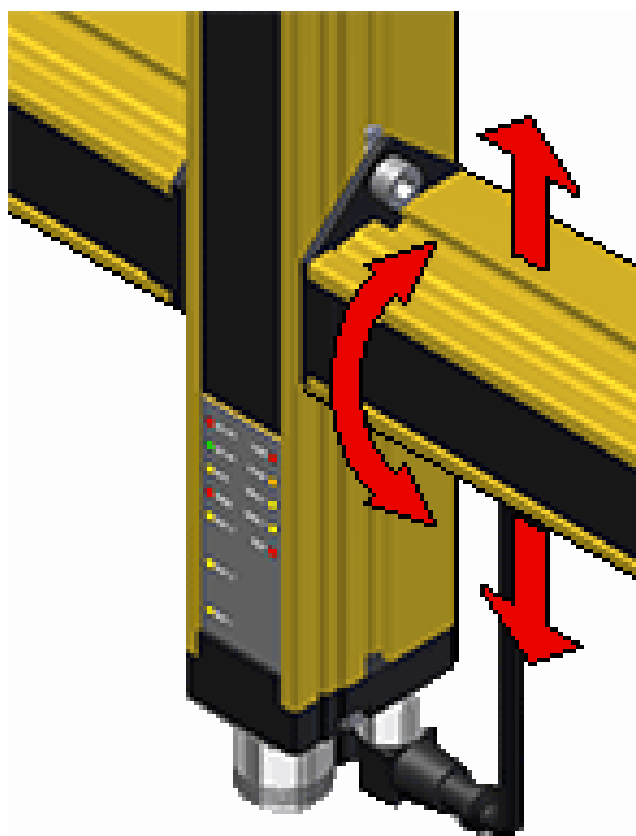

## ACCESSORIES

### BRACKETS

#### KIT brackets type "STVB"

Supplied as standard with the barrier.

It is the more complete bracket: it is composed from two units ( VB1 and VB2 ) that allow the rotation of the light curtain on the 3 axes in order to regulate the alignment of TX and RX unit.

They include :

- 4 brackets VB1
- 4 brackets VB2
- 4 washers Ø 6
- 4 screws M 6 X 8
- 8 screws M 5 X 8

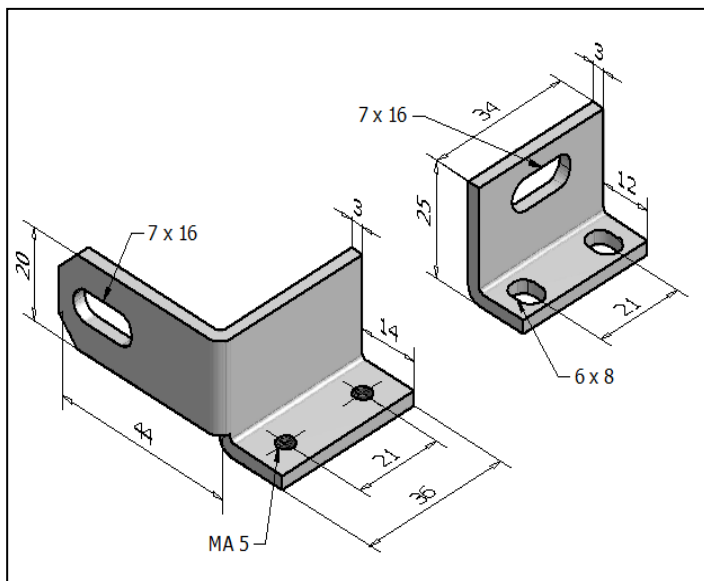

**Brackets type VB1 / VB2**

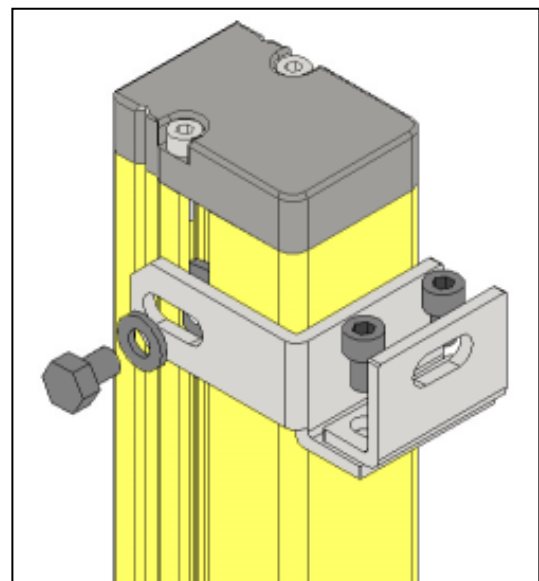

**Brackets STVB assembled**

#### NOTE :

To rotate the flowing insert, in order to insert them in the opposite guide of the aluminium enclosure, is necessary to remove the end cap without the connector, unscrewing the two screws.



**KIT OF BRACKETS "STGM"**

supplied as optional to STVB kit

Is formed by a one bracket "L" shape that is used for the angular regulation of the barrier. The sliding insert inside the aluminium profile allows the sliding of the light curtain in the height to facilitate its correct positioning.

Content :

- 4 brackets GM
- 4 washers  $\varnothing 6$
- 4 screws M 6 X 8

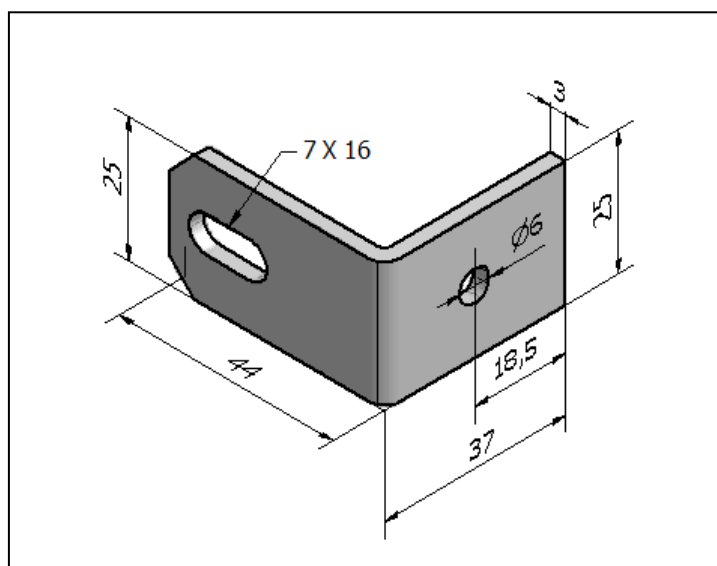

**Brackets type GM**

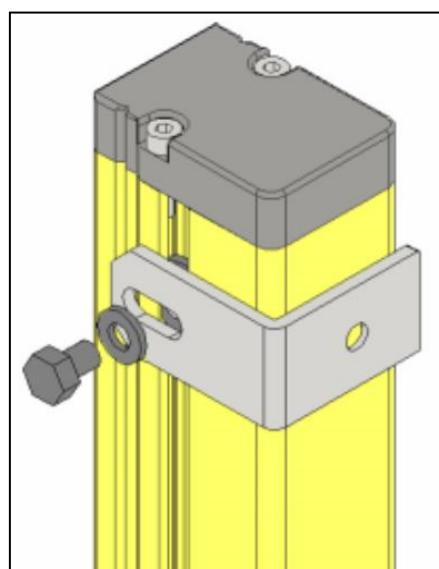

**Brackets STGM mounted**

**NOTE :**

To rotate the flowing insert, in order to insert them in the opposite guide of the aluminium enclosure, is necessary to remove the end cap without the connector, unscrewing the two screws.

**KIT OF BRACKETS “STDL”**

Supplied on request as alternative to mod. STVB

This brackets kit allows to stay the light curtain in its place established by fixing one of the brackets to the side of the light curtain, is recommended when there are needs or difficulties in the installation of light curtains.

Content:

- 4 brackets type VB1
- 4 brackets type VB3
- 4 washers Ø 6
- 4 screws M 6 X 8
- 8 screws M 5 X 8

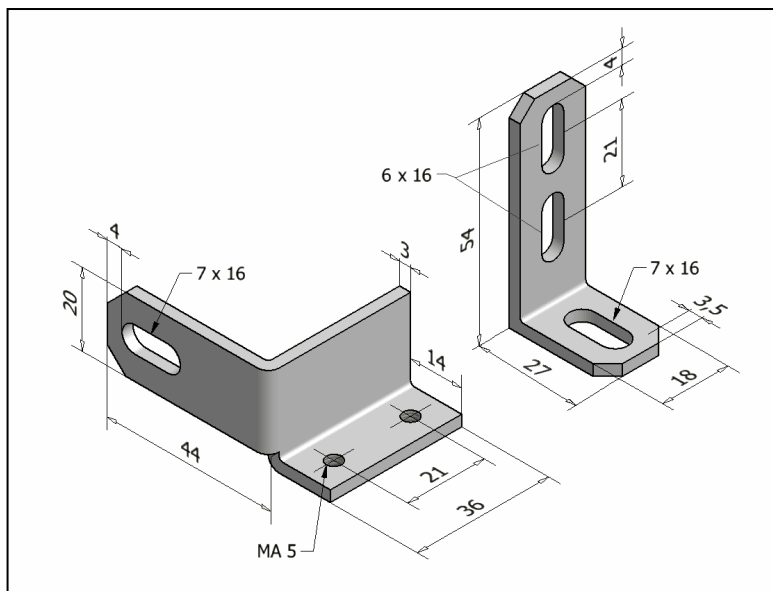

**Brackets type VB1**

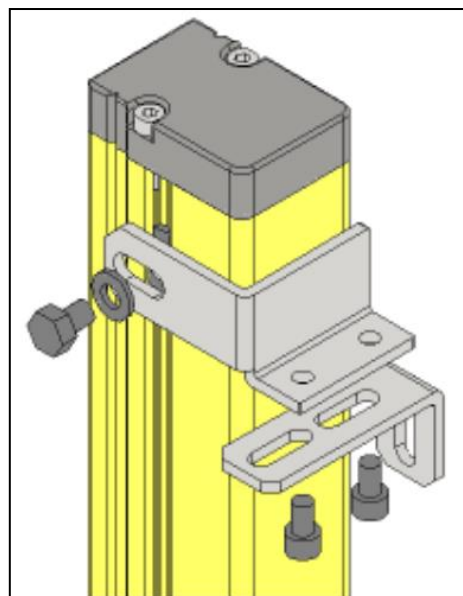

**Brackets type STDL mounted**

**NOTE:**

To rotate the flowing insert, in order to insert them in the opposite guide of the aluminium enclosure, is necessary to remove the end cap without the connector, unscrewing the two screws.

### CONNECTION CABLES

Description		Code	
<b>Connection cable Barrier - cabinet or relay module din rail</b>			
M12 / 4 pins, straight connector cable in PVC for TX	5m	E-74-5	
	10m	E-74-10	
M12 / 5 pins, straight connector cable in PVC for RX	5m	E-75-5	
	10m	E-75-10	
M12 / 8 pins straight connector, cable in PVC for RX	5m	E-78-5	
	10m	E-78-10	
<b>Connection cable barrier- to external relay module</b>			
M12 / 4 pins, 2 female right connector for TX - Rel 021/ 022	10m	E-104-10	
M12 / 5 pins, 2 female right connector for RX - Rel 021 / 022	10m	E-105-10	
M12 / 8 pins, 2 female right connector for RX - Rel 021 / 022	10m	E-108-10	

### INTEGRATED SIGNALLING LAMP

The optional lamp integrated inside the upper end cup of the barrier, provides information on the status of the OSSD and the MUTING function.

In the following table there are relationships between the state of the lamp and the active functions of the barrier.

CURTAIN STATE	END CAP COLOR
OSSD OFF	RED
OSSD ON	GREEN
MUTING ACTIVE	YELLOW

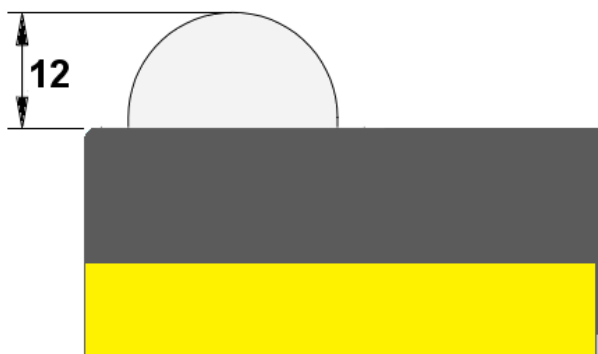

### RELAYS MODULE DIN RAIL



The following modules transform the static outputs of the light curtain into relays output. This modules can be mounted on DIN rail.

**REL 011** relay module standard - example of connection with external contactors control. The same wiring diagram can be applied to REL012.

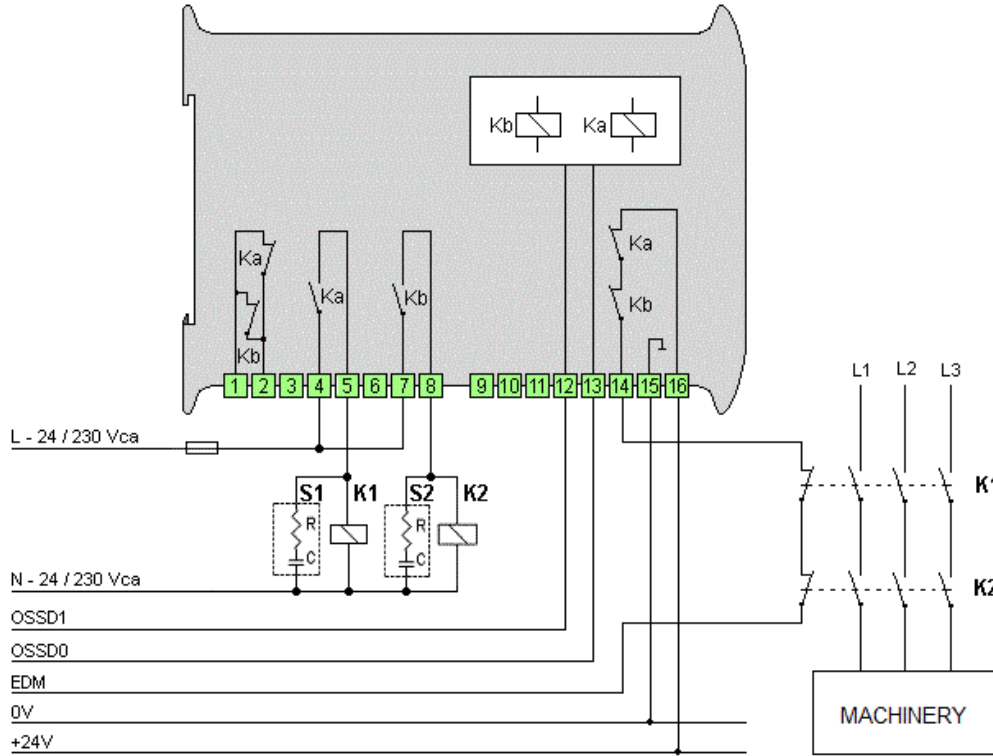

**REL 012** relay module with blinking muting lamp - example of connection

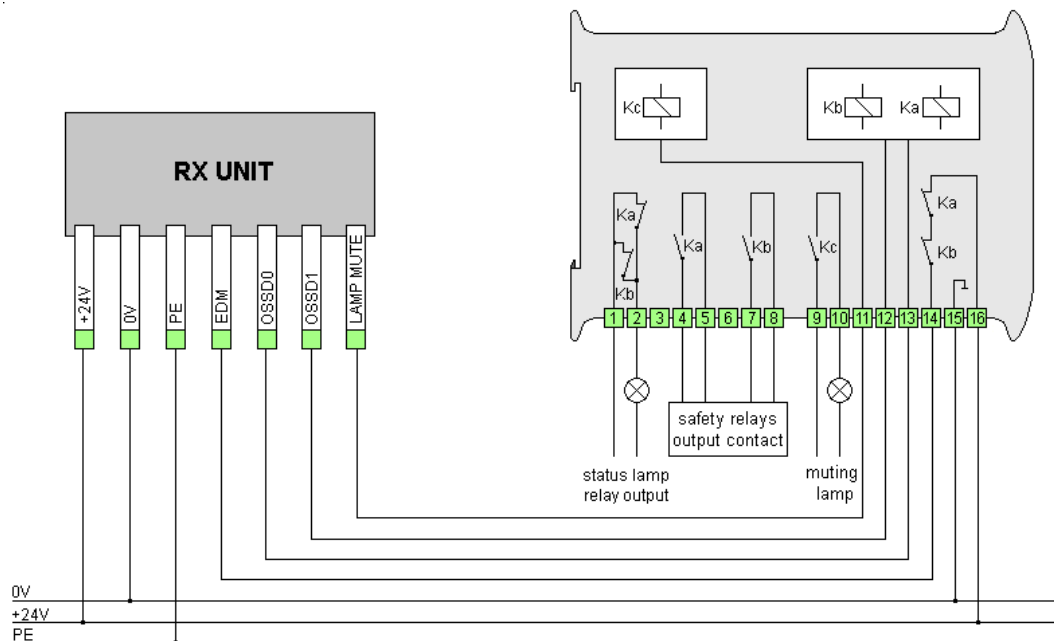

If not used the external contactors control, directly connect the pin 14 to the EDM input of the barrier.

**REL 013** Dual relay module – allows the connection of two barriers

Example of connection of two barriers that control two separate areas of the system by means of contactors. The correct operation of the module and contactors is controlled by the barriers via the EDM input.

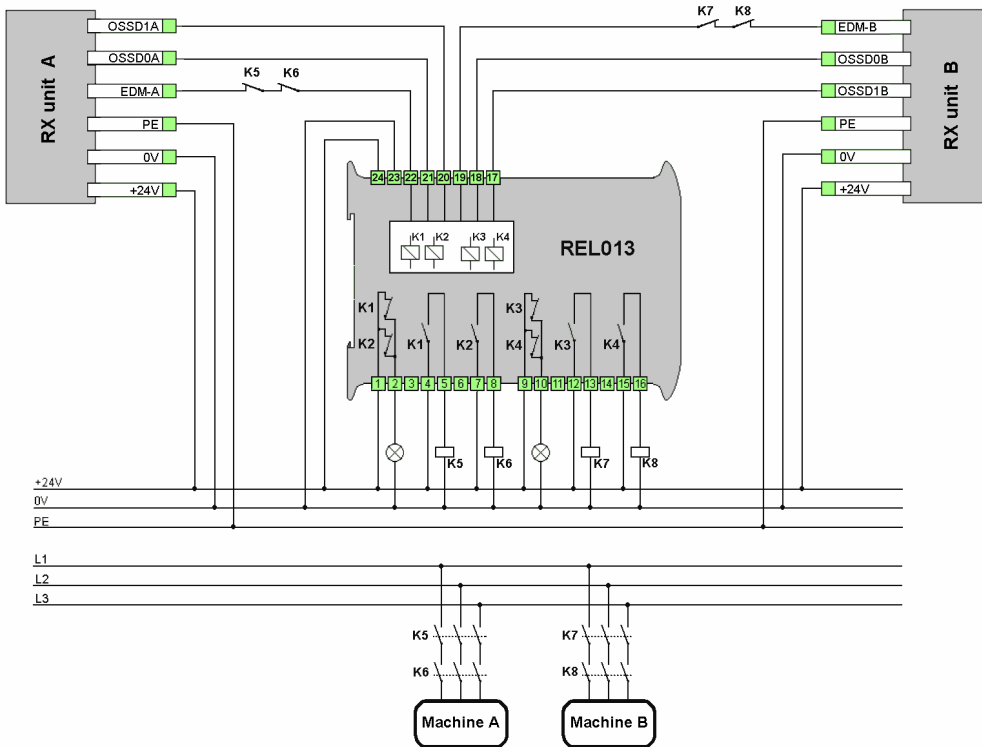

If not used the external contactors control, directly connect the pin 22 to EDM-A and the pin 19 to EDM-B input.

Connection diagram of two barriers that control a single machine (e.g. front-back protection). The correct operation of the module and contactors is checked by the barriers via the EDM inputs

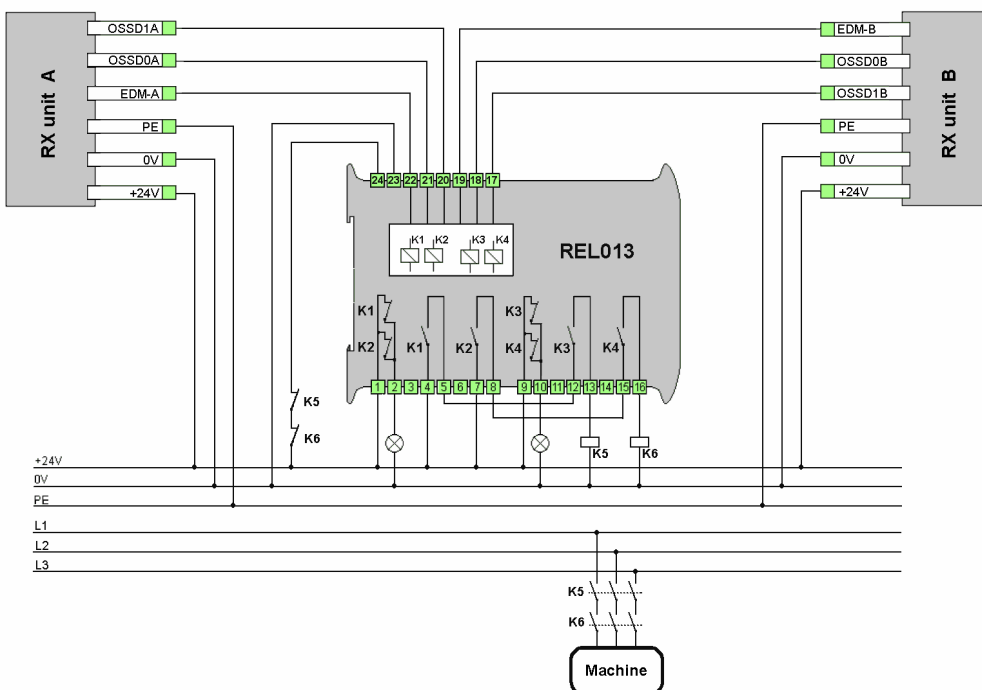

## EXTERNAL RELAY MODULES

**REL 022 E** relays module with spring-key for manual reset and guard override; OSSD status and MUTING lamp for **KP-e**



Example of connection with external contactor control.

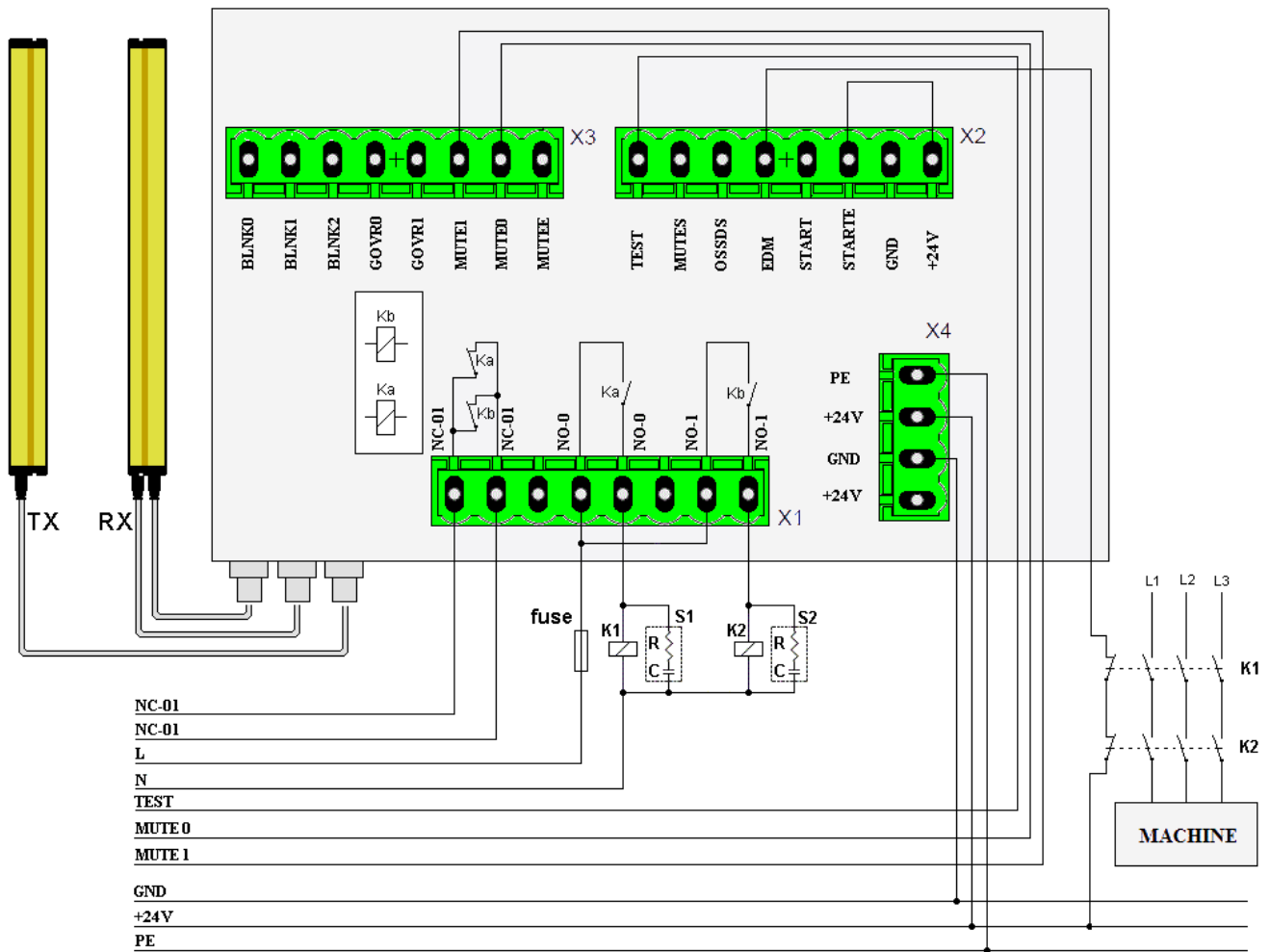

In this example the TEST signal is brought out of the module. The customer, with a N.O. contact can activate this function.  
 The signal STARTE is connected to +24V, so the manual reset is selected.  
 The signals MUTE0 and MUTE1 are brought out of the module to permit the connection at the external MUTING sensors.  
 The MUTE2, signal to enable the MUTING function, is connected to +24V inside the module.  
 The MUTING function is always active, is no possible de-activate it.

If not used the external contactors control, connect the EDM input to +24V of X2 connector.

**REL 022 E1** relays module with spring-key for manual reset and guard override; OSSD status and MUTING lamp for **KP-e1**



Allows setting of maximum muting time 1 minute / 90 minutes  
Provides MUTE-F output for signalling of busy barrier during muting.

Example of connection with contactor control.

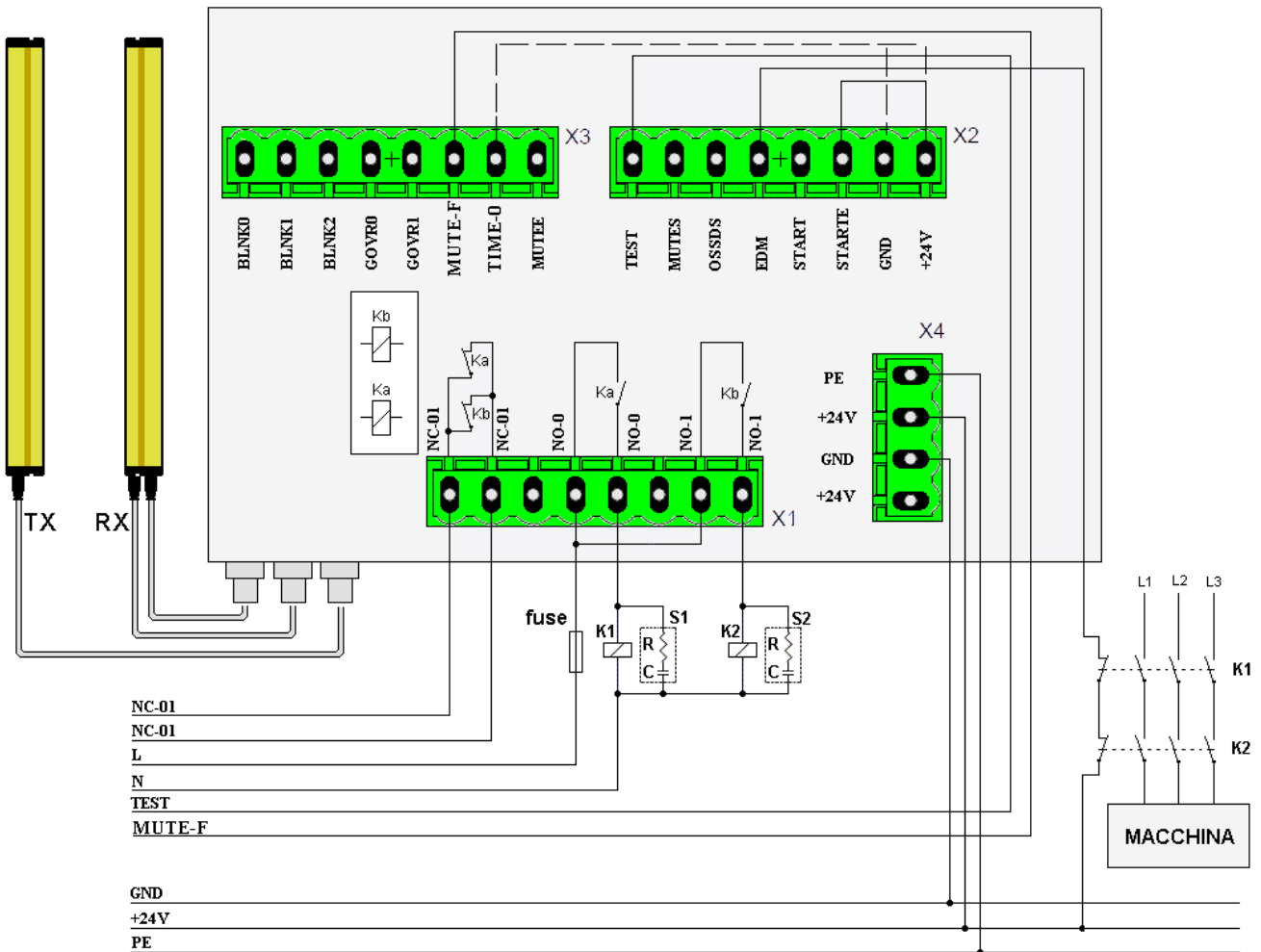

In this example the TEST signal is brought out of the module. The customer, with a N.O. contact can activate this function.

The signal START-E is connected to +24V, so the manual reset is selected.

The signals MUTE0 and MUTE1 are brought out of the module and connected to the MUTING sensors.

The MUTE-E is connected to +24 V inside the module, so the MUTING function is always active.

If not used the external contactors control, connect the EDM input to +24 Vdc of X2 connector.

The maximum muting time can be set via the TIME-0 terminal.

SETTING OF MUTING TIME	
TIME - 0	Maximum duration of muting time
0V	1 minute
+24V	90 minutes

**REL 022 E2** external relay module with reset key, Outputs Status Lamp, Muting Lamp, guard override key, for **KP-e2**.

Allows setting of maximum muting time 1 minute / 90 minutes  
Enables muting function via the MUTE-E input

Example of connection with external contactor control.

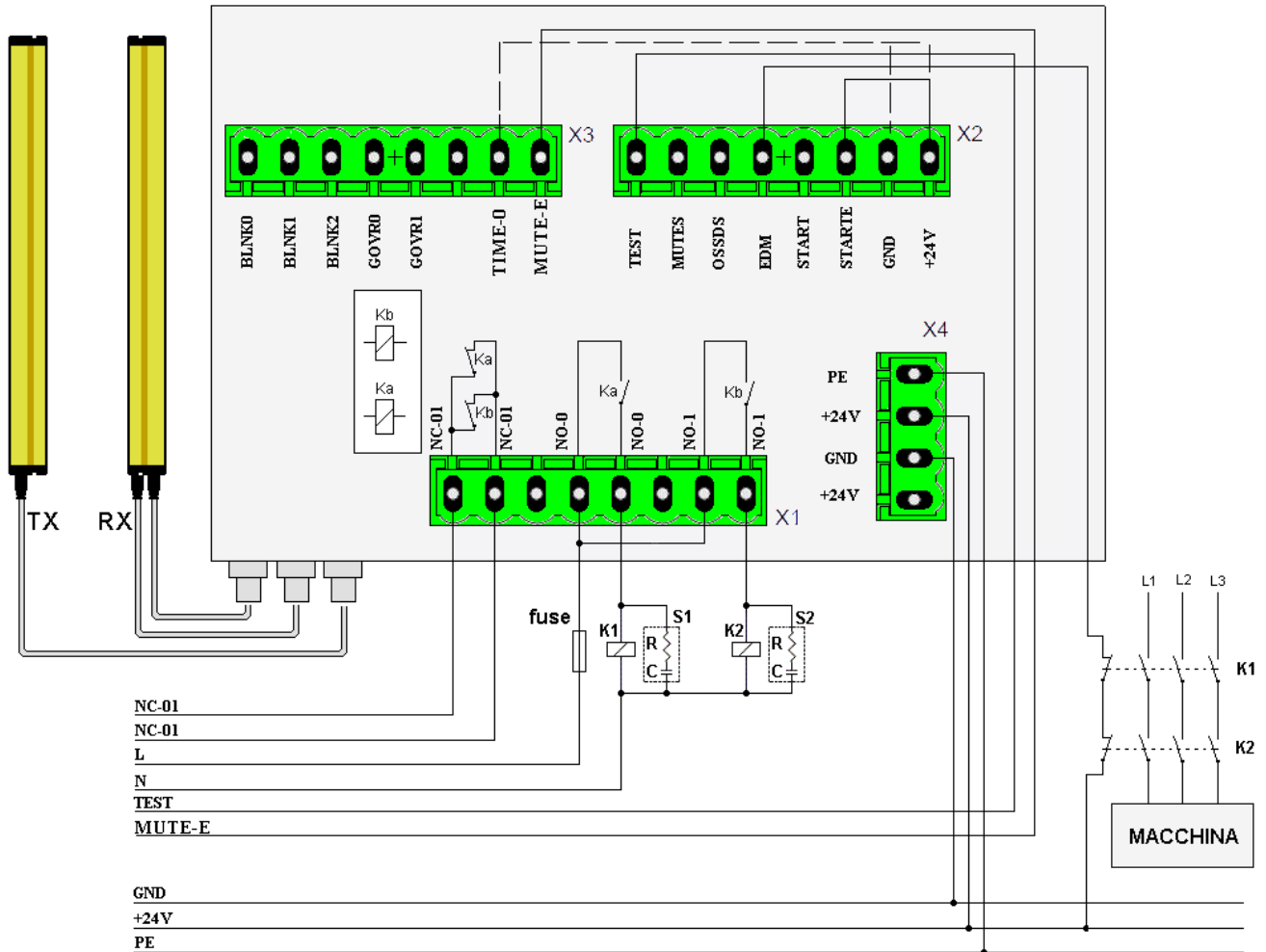

In this example, the TEST signal is remote outwards. This function can be activated via an N.O. contact.

The START-E signal is connected to +24 V, thus selecting manual reset.

If not used the external contactors control, connect the EDM input to +24 Vdc of X2 connector.

The maximum muting time can be set via the TIME-0 terminal.

SETTING OF MUTING TIME	
TIME - 0	Maximum duration of muting time
0V	1 minute
+24V	90 minutes



**REL 022 E3** external relay module with reset key, Outputs Status Lamp, Muting Lamp, guard override wrench, for **KP-e3**



The TIME-0 and TIME-1 pins are used to setup the maximum muting time, 1 minute, 90 minute, 24 hours.

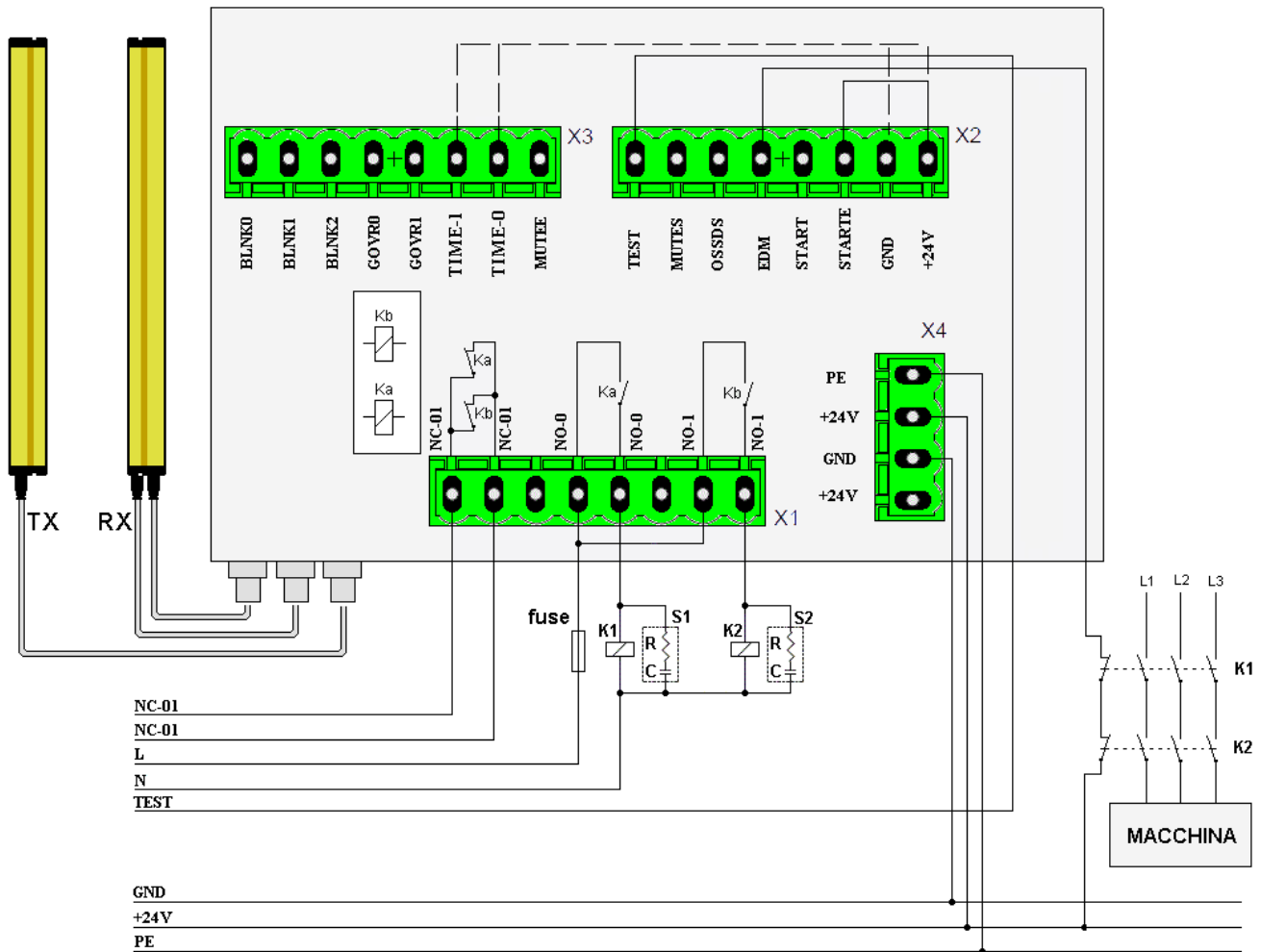

The MUTEE is connected to 24V internally, so the muting function is always active. The TEST signal can be lead outside to test the safety chain.

SETTINGS OF MAX MUTING TIME		
TIME - 0	TIME - 1	Maximum duration of the Muting
0V	0V	1 minute
0V	+24V	24 hours
+24V	0V	90 minutes
+24V	+24V	1 minute

If not used the external contactors control, connect the EDM input to +24 Vdc of X2 connector.

---

## Warranty

---

A guarantee is provided for a period of 12 months from the delivery date and terminates at the expiration of this term, even if the materials have not been used for any reason.

Our company undertakes to repair or replace, during this period, free of charge, within the shortest possible time, those parts which owing to poor quality of material or defective workman-ship or inaccurate assembly should prove defective. This is providing that defects are not due to:

- wear and tear
- failure caused by inexperience or negligence
- unauthorized intervention or tampering
- overloads behind contract limits
- accidental causes or "force major"

These repairs or replacements shall be performed AT OUR WORKSHOP in MILANO.  
Transport and workman-ship will be completely charged to purchaser.

Nothing will be owed to the purchaser for the time during which the plant may remain idle, nor shall he make claims or ask indemnity for charges, accidents or direct or indirect damages.

For anything else not specified or that becomes a subject of dispute, the ANIE (Italian Electrotechnical Industries Association) general sale conditions will be applied.

**GREIN S.p.A. Milan**

**NOTE: characteristics and dimensions reported in this manual are for reference only and they can be subject to change without notice.**

**DICHIARAZIONE “UE” DI CONFORMITA’  
“UE” DECLARATION OF CONFORMITY****Il fabbricante****The manufacturer****GREIN S.p.A.**

Via S.G.B. De La Salle 4/A 20132 MILANO ITALY

**Dichiara che****Declares that**I prodotti identificati come "KEEPER" sono  
Dispositivi Elettrosensibili di Sicurezza (ESPE)  
Versione 2106 di:The products identified with the name "KEEPER"  
are Device for protection of dangerous area (ESPE)  
Version 2106 of:

Tipo 4, SIL 3, Cat 4 – PL e

Type 4, SIL 3, Cat 4 – PL e

**Organismo Notificato****Notified Body****TUV CYPRUS LTD N identificazione 2261****2 Papaflessas str., 2235 Latsia****P.O BOX 20732, 1663 Nicosia****Country : Cyprus****N attestato esame CE del tipo N TÜV CY 22 MD 020567**

Conformi alle seguenti direttive

Conforms to the following directives

2006 / 42 / EC Direttiva Macchine  
come attuata dal DLGS N17 del 27 gen 2010  
2014 / 30 / EC Compatibilità Elettromagnetica  
come attuata dal DLGS N 80 del 18 mag 2016Machine Directive  
Electro Magnetic Compatibility Directive

Norme armonizzate utilizzate

Harmonized standards used

EN 61496-1: 2013, EN 61000-6-2: 2005, EN 61000-6-4: 2007 + A1: 2011  
EN 62061: 2005 + AC: 2010 + A1: 2013 + A2: 2015  
EN ISO 13849-1: 2015, EN ISO 13849-2: 2012

Altre norme e specifiche tecniche utilizzate

Other technical standards and specifications used

EN 61496-2: 2013, EN 61508-3: 2010

Persona autorizzata a costituire il fascicolo tecnico

Person authorized to compile the technical file

NAME Begozzi Roberto  
POSITION C E O GREIN S.p.A.

Grein S.p.A.. Via S.G.B. De La Salle 4/A 20132 MILANO ITALY

Milano, 2 gen 2023

  
**GREIN S.P.A.**  
**Amministratore Unico**

Originale / Original

La presente dichiarazione di conformità è rilasciata sotto la responsabilità esclusiva del fabbricante  
This declaration of conformity is issued under the sole responsibility of the manufacturer.

# GREIN



Via S. G. B. De la Salle 4/A 20132 Milano - MI Tel 02 26300140 Fax 02 26300711  
[www.grein.it](http://www.grein.it) | [info@grein.it](mailto:info@grein.it)